

TECHNICAL MANUAL

**OPERATOR, UNIT, INTERMEDIATE
SUPPORT MAINTENANCE MANUAL
(INCLUDING REPAIR PARTS AND
SPECIAL TOOLS LIST)**

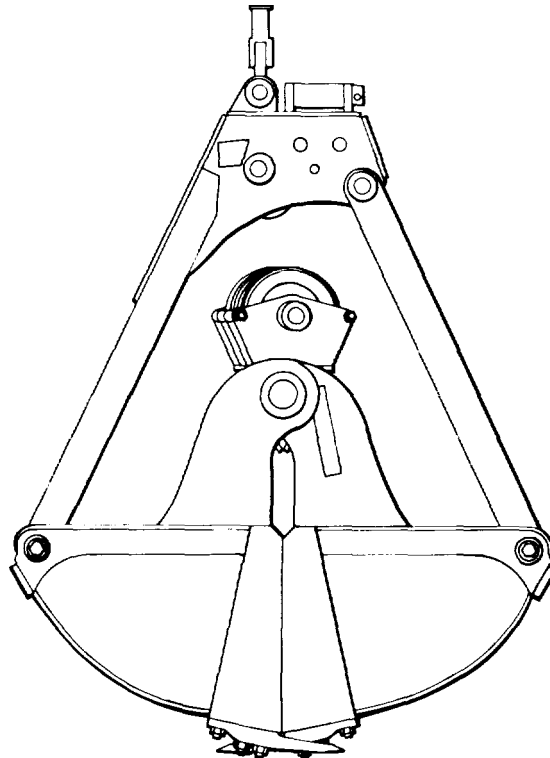

**BUCKET, CLAMSHELL, TYPE II SIZE 75
3/4 CU. YD. GENERAL PURPOSE
INTERGY MODEL 34GP S
NSN 3815-01-249-4092**

**HEADQUARTERS, DEPARTMENT OF THE ARMY
23 DECEMBER 1988
APPROVED FOR PUBLIC RELEASE; DISTRIBUTION UNLIMITED**

CHANGE

NO. 1

HEADQUARTERS
DEPARTMENT OF THE ARMY
Washington D.C., 30 November 1992

**OPERATOR, UNIT, INTERMEDIATE SUPPORT MAINTENANCE MANUAL
(INCLUDING REPAIR PARTS AND SPECIAL TOOLS LIST)**

**BUCKET, CLAMSHELL, TYPE II SIZE 75
3/4 CU. YD. GENERAL PURPOSE
INTERGY MODEL 34GP S
NSN 3815-01-249-4092**

Current as of 28 September 1992

TM 5-3815-225-13&P, 23 December 1988, is changed as follows:

1. Remove old pages and insert new pages.
2. New or changed material is indicated by a vertical bar in the margin.

Remove Pages

i and ii

N-1 through Sheet 13 of 13

Insert Pages

i through iii/(iv Blank)

N-1 through N-7

3. File this change sheet in front of the publication for reference purposes.

By Order of the Secretary of the Army:

GORDON R. SULLIVAN
General, United States Army
Chief of Staff

Official:

MILTON H. HAMILTON
Administrative Assistant to the
Secretary of the Army
03166

Distribution:

To be distributed in accordance with DA Form 12-25-E, Block No. 3625, Operator, Unit, Direct Support and General Support Maintenance Requirements for TM 5-3815225-13&P.

Approved for public release; distribution is unlimited.

**OPERATOR, UNIT, INTERMEDIATE SUPPORT MAINTENANCE MANUAL
(INCLUDING REPAIR PARTS AND SPECIAL TOOLS LIST)**

FOR

**BUCKET, CLAMSHELL, TYPE II SIZE 75
3/4CU. YD. GENERAL PURPOSE
INTERGY MODEL 34GP S
NSN 3815-01-249-4092**

REPORTING ERRORS AND RECOMMENDING IMPROVEMENTS

You can help improve this manual. If you find any mistakes or if you know of a way to improve the procedures, please let us know. Mail your letter, DA Form 2028 (Recommended Changes to Publications and Blank Forms), or DA Form 2028-2, located in the back of this manual, direct to: Commander , U.S. Army Tank-Automotive Command, ATTN: AMSTA-MB, Warren, MI 48397-5000. A reply will be furnished to you.

This technical manual is an authentication of the manufacturers commercial literature and does not conform with the format and content specified in AR 310-3, Military Publications. This technical manual does, however, contain available information that is essential to the operation and maintenance of the equipment.

TABLE OF CONTENTS

TITLE	PAGE
Safety Precautions	a
Clamshell Specifications	1
Shipping Instructions	1
Storage Instructions.....	1
General Description.....	2

Distribution Restriction: Approved for public release; distribution is unlimited.

TABLE OF CONTENTS

TITLE	PAGE
Clamshell Nomenclature	3
Installation Instructions.....	5
Lubrication & Inspection	9
Lubrication Chart	10
Maintenance Instructions	
Socket & Link	11
Rollers	12
Upper Arm Pin	13
Arm Bar	15
Corner Bracket.....	16
Lower Block & Main Shaft.....	18
Closing Sheave.....	21
Lip & Bowl	23
Tooth.....	27
Disassembly Instructions & Illustrations	
Head & Arm Instructions	28
Lower Block, Bowl & Hinge Instructions.....	36
Sheave Bushing	41
Tool List.....	42
Troubleshooting Guide	43
Warranty	44
Supplemental Operating, Maintenance and Repair Parts Instructions.....	47
APPENDIX A. Maintenance Allocation Chart	A-1
APPENDIX B. Operator/Crew PMCS	B-1
APPENDIX C. Additional Authorized Items.....	C-1
APPENDIX D. Maintenance and Operating Supply List.....	D-1
APPENDIX E. DA Equipment Publications.....	E-1
APPENDIX F. Lubrication Order.....	F-1
APPENDIX G. Sample DA Form 2765 Part Number Request.....	G-1
APPENDIX H. DSS Project Codes	H-1
APPENDIX I. Sample MILSTRIP Requisition.....	I-1
APPENDIX J. Sample MILSTRIP Requisition	J-1
APPENDIX K. Sample MILSTRIP Requisition (manual)	K-1
APPENDIX L. Requisition Form T.....	L-1
APPENDIX M. NSN Format	M-1

TABLE OF CONTENTS

	ILLUS FIG	PAGE
APPENDIX N. Repair Parts and Special Tools Lists		N-1
Section I. Introduction.....		N-1
Section II. Repair Parts List.....		1-1
GROUP 74 CRANES, SHOVELS, AND EARTHMOVING EQUIPMENT COMPONENTS		
7411 - CRANE DRAGLINE OR CLAMSHELL ATTACHMENTS		1-1
BOWL ASSEMBLY (INSIDE HINGES)	1	1-1
BOWL ASSEMBLY (OUTSIDE HINGES)	2	2-1
LOWER BLOCK ASSEMBLY	3	3-1
HEAD ASSEMBLY	4	4-1
PIVOT ARM ASSEMBLY	5	5-1
TOOTH EQUIPMENT	6	6-1
Section III. Special Tools (Not Applicable)		
Section IV. Cross-reference Indexes		
NATIONAL STOCK NUMBER INDEX		I-1
PART NUMBER INDEX		I-2
FIGURE AND ITEM NUMBER INDEX.....		I-4

Change 1 iii/(iv Blank)

SAFETY PRECAUTIONS

READ THIS MANUAL

EVEN THOUGH YOU MAY BE FAMILIAR WITH CLAMSHELL BUCKET OPERATION. SAFETY PROCEDURES, HOOK-UP DIRECTIONS AND MAINTENANCE REQUIREMENTS ARE THOROUGHLY DISCUSSED. FOR REFERENCE, AN ILLUSTRATION OF THIS BUCKET HAS BEEN PLACED ON PAGES 3 AND 4 OF THIS MANUAL. PARTS ORDER INFORMATION SUCH AS BUCKET TYPE, SIZE, MODEL NUMBER AND SERIAL NUMBER ARE ON THE FRONT.

THE OPERATING AND MAINTENANCE RECOMMENDATIONS IN THIS MANUAL REQUIRE VERY LITTLE TIME AND EXPENSE. HOWEVER, COMPLIANCE WITH THESE RECOMMENDATIONS WILL RESULT IN LOWER OPERATING COSTS AND SAFE, PRODUCTIVE OPERATION.

****** WARNING ******

DO NOT REMOVE BOWL RESTRAINTS BEFORE UNPACKING YOUR BUCKET.

YOUR BUCKET HAS BEEN SECURED AT THE FACTORY TO PREVENT MOVEMENT DURING SHIPMENT. BECAUSE IT IS A CLAMSHELL TYPE BUCKET, IT MAY OPEN UNEXPECTEDLY IF ANY ATTEMPT IS MADE TO LIFT OR RE-POSITION IT WITH THESE RESTRAINTS REMOVED. ONLY AFTER THE BUCKET IS PLACED UNDER THE CRANE AND IS PROPERLY INSTALLED AND READY FOR USE SHOULD THE FASTENING BE REMOVED.

FAILURE TO FOLLOW THIS PROCEDURE MAY CAUSE PERSONAL INJURY AND/OR BUCKET DAMAGE.

****** WARNING ******

USE CORRECT CABLE. THE SHEAVES, WEDGES, AND SOCKETS OF THIS BUCKET ARE DESIGNED TO USE A PARTICULAR SIZE OF WIRE ROPE CABLE (SEE ILLUSTRATION TABLE NO. 1 FOR PROPER WIRE ROPE SIZE). OTHER SIZE CABLES MAY NOT SEAT PROPERLY AND BECOME LOOSE. AS AN EXTRA PRECAUTION, INSTALL CABLE CLAMPS ON THE LOOSE ENDS OF THE CABLE AFTER IT EMERGES FROM THE ROPE SOCKET (SEE TABLE NO.1) PAGE 7.

GENERAL DESCRIPTION

CLAMSHELL BUCKET
 TYPE II GENERAL PURPOSE
 SIZE 75 3/4 CU.YD.
 MODEL NUMBER 34GPS

SHIPPING CUBE LENGTH 6'-9", HEIGHT 5'-1", WIDTH 3'-0"

TOTAL WEIGHT 3,150 LBS.

HEIGHT OPEN 9'-4"

HEIGHT CLOSED 7'-8"

LENGTH OPEN 7'-3"

LENGTH CLOSED 5'-6"

WIDTH OVERALL 3'-0"

CABLE TO REEVE 51'-0"

CABLE TO CLOSE 28'-0"

DECK AREA 20.6 SQ.FT.

SHIPPING INSTRUCTIONS

REMOVE ALL DIRT AND MUD FROM CLAMSHELL BUCKET. WELD BOWL RESTRAINTS ON TO BOWL SIDES WITH CLAMSHELL IN CLOSED POSITION. REMOVE HOLDING AND CLOSING LINES FROM CLAMSHELL. SECURE HOLDING LINE AND CLOSING LINE SOCKET WEDGES INTO SOCKET BOWLS WITH WIRE. CLAMSHELL IS NOW READY FOR SHIPPING.

CLAMSHELL STORAGE

CLAMSHELL STORAGE SHORT TERM 60 DAYS OR LESS. STORAGE CAN BE INSIDE OR OUTSIDE. GREASE ALL POINTS OF ROTATION WHEN CLAMSHELL IS FIRST PUT IN STORAGE. ENSURE ALL NUTS, BOLTS, COTTER PINS, AND SOCKET WEDGES ARE INSTALLED ON THE CLAMSHELL.

CLAMSHELL STORAGE LONG TERM 60 DAYS OR MORE. STORAGE CAN BE INSIDE OR OUTSIDE. GREASE ALL POINTS OF ROTATION WHEN CLAMSHELL IS FIRST PUT IN STORAGE. ENSURE ALL NUTS, BOLTS, COTTER PINS, AND SOCKET WEDGES ARE INSTALLED ON THE CLAMSHELL. EVERY 60 DAYS ROTATE SHEAVES AND CABLE ROLLERS TO ENSURE FREE ROTATION. EVERY 60 DAYS GREASE ALL POINTS OF ROTATION.

GENERAL DESCRIPTION

READ THIS INTRODUCTION EVEN THOUGH YOU MAY BE FAMILIAR WITH CLAMSHELL BUCKET OPERATION. ILLUSTRATIONS OF THIS BUCKET ARE ON PAGES 6 AND 7 OF THIS MANUAL. PERTINENT PARTS ORDERING INFORMATION SUCH AS BUCKET TYPE, SIZE, MODEL NUMBER AND SERIAL NUMBER ARE ON THE FRONT OF THIS MANUAL.

THE CLAMSHELL BUCKET IS A JACK OF ALL TRADES. IT CAN DO MOST OF THE JOBS OTHER BUCKETS CAN DO. THE CLAMSHELL HAS ITS OWN SPECIALTY OF DIGGING DEEP, NARROW, STRAIGHT-SIDED EXCAVATIONS, WITH NEAT REHANDLING OF MATERIALS. THIS GENERAL PURPOSE CLAMSHELL IS DESIGNED TO EXCAVATE, REHANDLE AND DREDGE MATERIALS IN A LOOSE OR SLIGHTLY COMPACTED STATE. IT WILL OPERATE EFFECTIVELY IN MATERIALS WEIGHING UP TO 130 POUNDS PER CUBIC FOOT.

THE CLAMSHELL IS A SINGLE MAIN SHAFT, BLOCK AND TACKLE TYPE OF CONSTRUCTION. THE CLAMSHELL IS DESIGNED TO USE ITS WEIGHT, PITCH OF TEETH, SHARPNESS AND ANGLE OF THE LIP IN CONNECTION WITH THE MACHINE LINE PULL TO DRAW THE BUCKET DOWNWARD INTO THE MATERIAL. THE CLAMSHELL MUST ALWAYS BE PLACED IN THE MATERIAL IN THE OPEN POSITION TO START ITS DIGGING CYCLE.

THE CLAMSHELL CLOSING MECHANISM IS THE BLOCK AND TACKLE ARRANGEMENT OF THE CLOSING SHEAVES. AS THE CLOSING LINE FROM THE MACHINE PULLS ON THE SHEAVES THE BOWL HALVES PIVOT AROUND THE MAIN SHAFT. AS THE CABLE IS PULLING THE TWO SETS OF SHEAVES TOGETHER A POWERFUL CLOSING FORCE IS DEVELOPED BETWEEN THE BOWL HALVES. SINCE THE ARM BARS ARE FIXED AND WILL NOT ALLOW THE OUTER ENDS OF THE BOWLS TO RISE, THE BOWLS PIVOT ON THEIR HINGES AND ROTATE INWARD UNTIL THEY MEET. THE BUCKET IS NOW CLOSED, AND WILL PICK UP ITS LOAD IF RAISED. IF THE CLOSING LINE IS RELEASED WHILE THE BUCKET IS HELD IN THE AIR BY THE HOLDING LINE, GRAVITY WILL CAUSE THE MAIN SHAFT TO MOVE DOWN PUSHING THE BOWLS DOWNWARD AND OUTWARD AND DUMP THE LOAD.

MATCH THE CLAMSHELL BUCKET TO THE CAPACITY OF THE CRANE FOR MAXIMUM EFFICIENCY. OPERATING EFFICIENCY IS DETERMINED BY THE WORKING RADIUS, BOOM LENGTH, MACHINE COUNTER-WEIGHT AND ENGINE CAPACITY. A TABLE OF LIFTING CAPACITIES WILL BE IN THE CRANE, THE WEIGHT OF THE BUCKET AND LOAD SHOULD NOT EXCEED THIS CAPACITY.

CLAMSHELL NOMENCLATURE

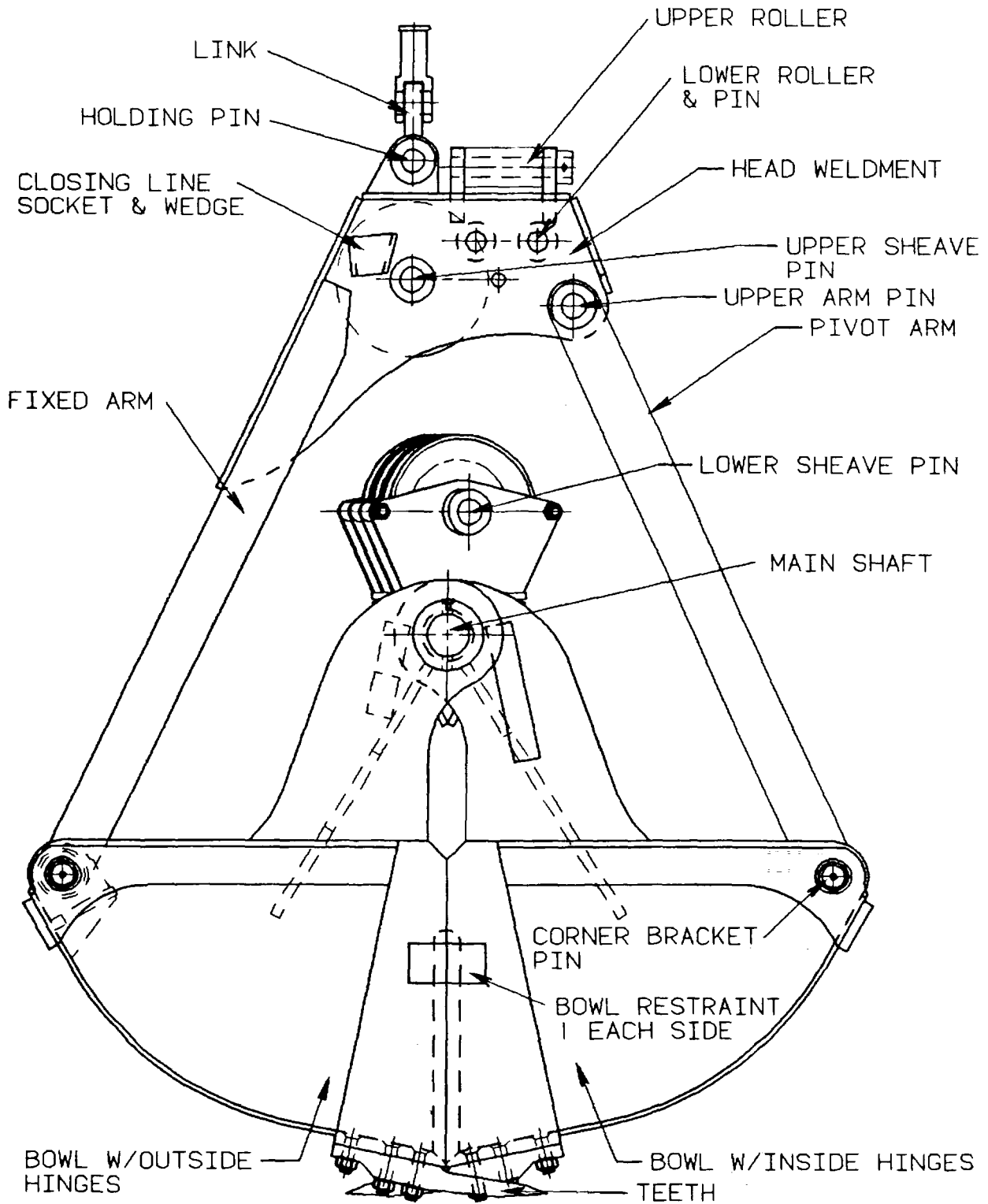

CLAMSHELL NOMENCLATURE

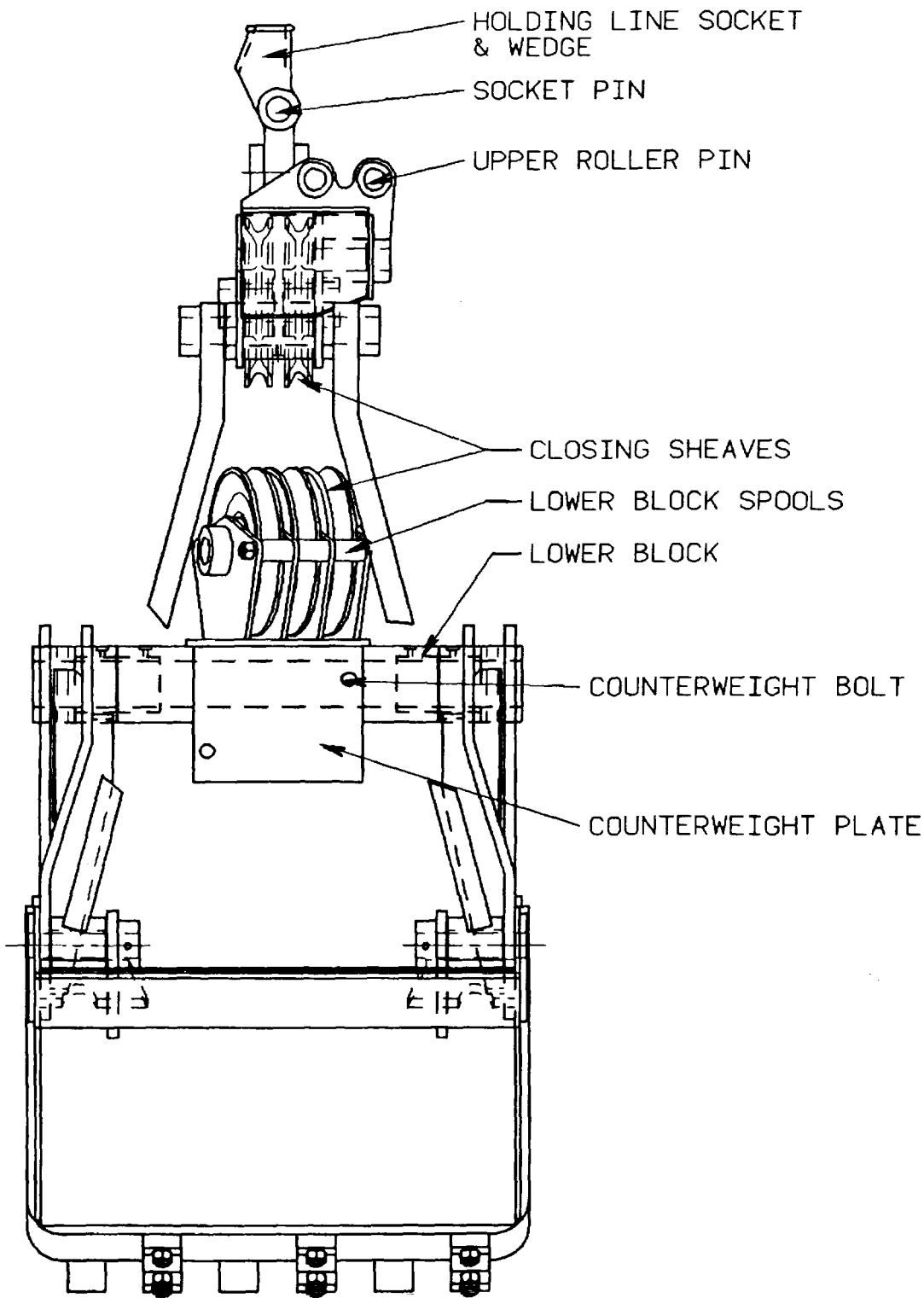

INSTALLATION INSTRUCTIONS

**** WARNING ****

WEAR OSHA APPROVED HARD HATS, SAFETY GLASSES, SAFETY SHOES AND WORK GLOVES WHEN PERFORMING MAINTENANCE WORK.

- I. LOCATE HOLDING LINE SOCKET AND REMOVE WEDGE. SEE ILLUSTRATION I

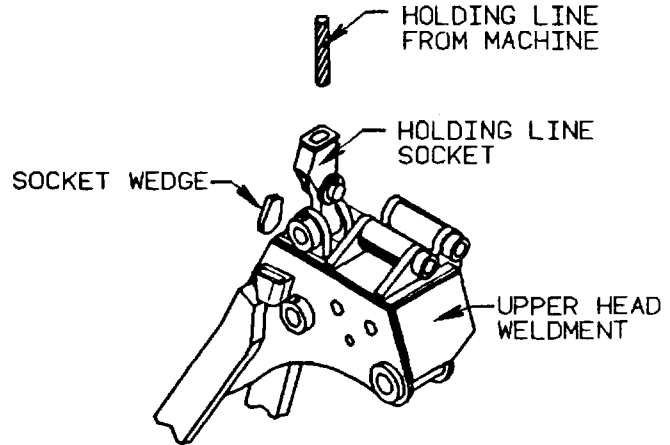

ILLUSTRATION I

- 2. INSERT HOLDING LINE FROM MACHINE INTO HOLDING SOCKET AND SECURE WITH SOCKET WEDGE. SEE ILLUSTRATION NO.2 EXTEND DEAD END OF ROPE 12 INCHES THROUGH SOCKET SECURE WITH CLAMPS SEE TABLE I PAGE 7

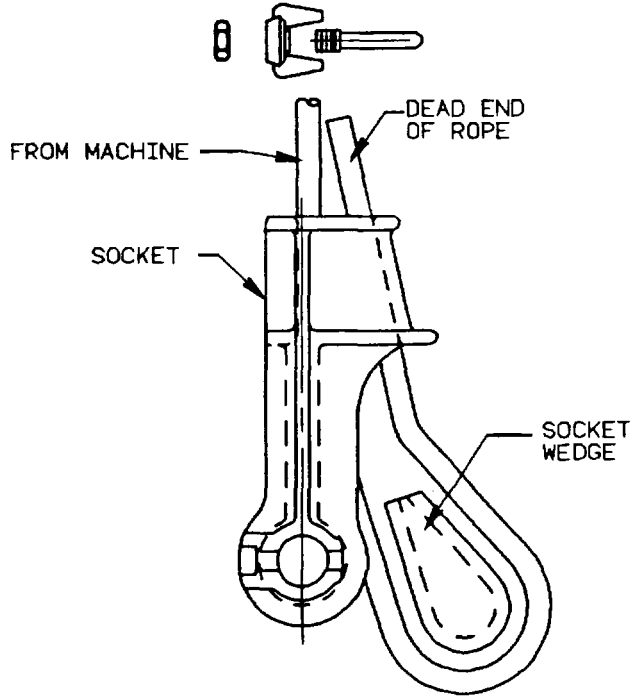

ILLUSTRATION NO. 2

INSTALLATION INSTRUCTIONS

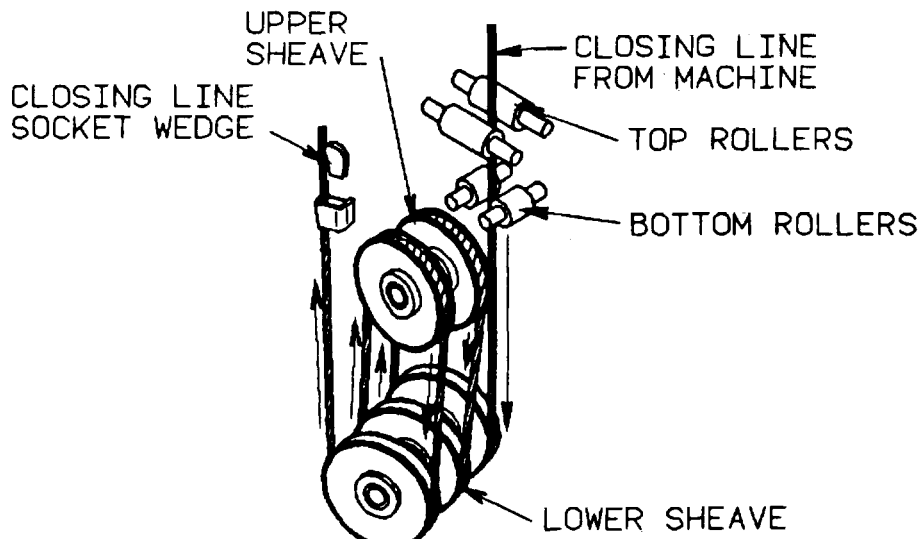

ILLUSTRATION NO.3

3. LOCATE AND REMOVE CLOSING LINE SOCKET WEDGE.
4. TO REEVE THE CLOSING SHEAVES, PASS THE CABLE DOWN BETWEEN THE UPPER ROLLERS AND REEVE AROUND THE LOWER SHEAVE DIRECTLY BELOW. CONTINUE REEVEING TO THE SHEAVE DIRECTLY ABOVE. THE LEADS WILL BE STRAIGHT FROM THE GROOVE OF ONE SHEAVE TO THE GROOVE OF THE NEXT ONE. SEE ILLUSTRATION 3 SHOWING REEVEING THE PARTS OF LINE.
5. INSERT CLOSING LINE FROM MACHINE INTO CLOSING LINE SOCKET AND SECURE WITH SOCKET WEDGE SEE ILLUSTRATION 4.

EXTEND DEAD END OF WIRE ROPE 12 INCHES THROUGH SOCKET SECURE WITH CLAMPS SEE TABLE I PAGE 7 .

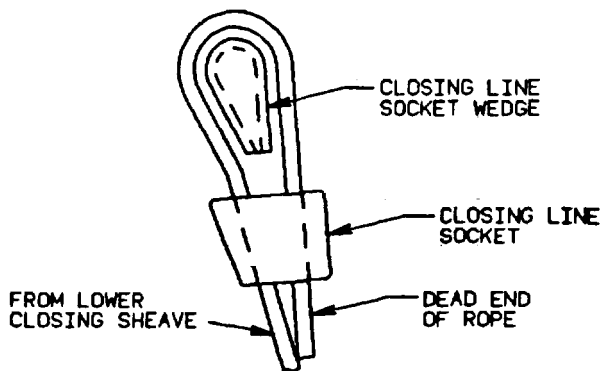

ILLUSTRATION NO.4

INSTALLATION INSTRUCTIONS

- 6. CHECK BUCKET BEFORE HOISTING ALL PIN, PINLOCKS MUST BE IN PLACE AND TIGHT. ALL SOCKET WEDGES MUST BE IN SOCKETS TIGHT.
- 7. REMOVE BUCKET BOWL RESTRAINTS (ARC AIR/CUTTING TORCH) SEE CLAMSHELL NOMENCLATURE PAGE 6.(NEW BUCKETS ONLY)
- 8. PRIOR TO DIGGING OPERATION MAKE **4 OR 5** PASSES WITH BUCKET. RECHECK ALL SOCKETS AND WEDGES TO INSURE WIRE ROPE IS PROPERLY SEATED.

**** **WARNING** ****

WEAR OSHA APPROVED HARD HATS, SAFETY GLASSES, SAFETY SHOES AND WORK GLOVES WHEN PERFORMING MAINTENANCE WORK.

TABLE I

DIAMETER OF ROPE (INCHES)	NUMBER OF CLIPS	CENTER-TO-CENTER SPACE BETWEEN CLIPS (INCHES)	LENGTH OF WIRE ROPE TURNED BACK EXCLUSIVE OF EYE (INCHES)
5/8	3	3 3/4	12

TO GET THE MAXIMUM STRENGTH FROM A CONNECTION, CLAMPS WILL BE INSTALLED BY THE METHOD ILLUSTRATED.

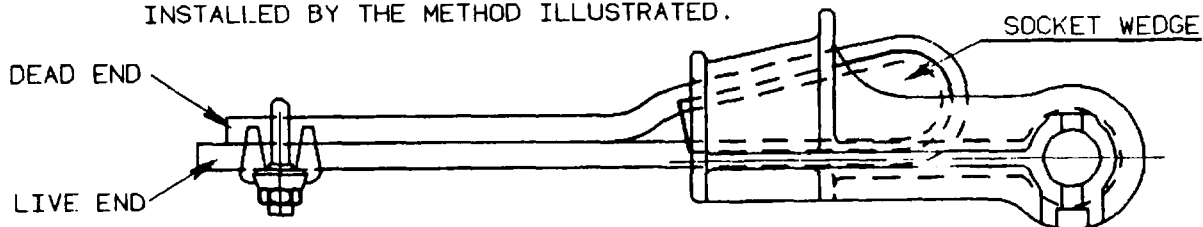

STEP 1. APPLY FIRST CLAMP-ONE SADDLE WIDTH FROM DEAD END OF WIRE ROPE U-BOLT OVER DEAD END-LIVE END RESTS IN CLIP SADDLE. TIGHTEN NUTS EVENLY.

INSTALLATION INSTRUCTIONS

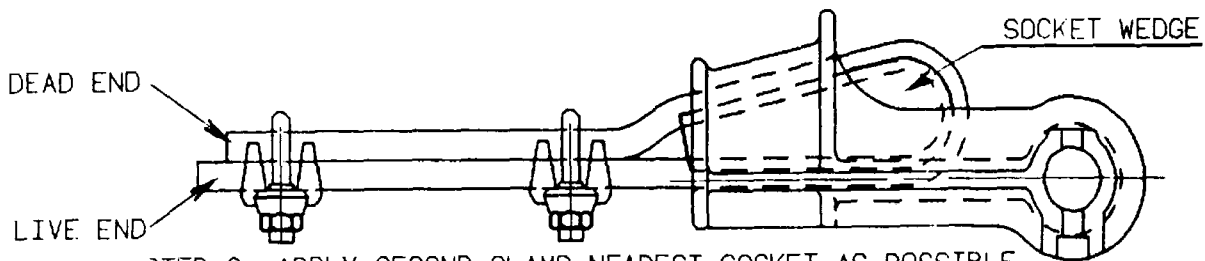

STEP 2. APPLY SECOND CLAMP-NEAREST SOCKET AS POSSIBLE
U-BOLT OVER DEAD END-TURN ON NUTS FIRM BUT DO NOT TIGHTEN

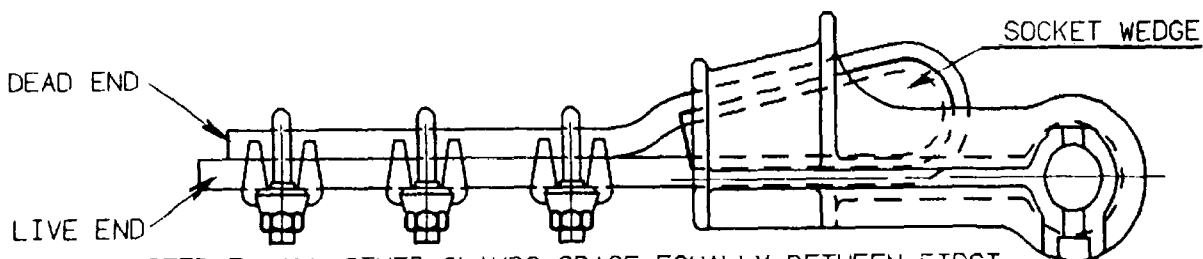

STEP 3. ALL OTHER CLAMPS-SPACE EQUALLY BETWEEN FIRST
TWO-THIS WILL BE NO MORE THAN ONE CLAMP SADDLE APART
TURN ON NUTS-TAKE UP ROPE SLACK TIGHTEN ALL NUTS EVENLY
ON ALL CLAMPS TO RECOMMENDED TORQUE. (TORQUE 109 FT LB)

DAILY LUBRICATION AND INSPECTION

1. LUBRICATE ALL ROTATION POINTS EVERY 8 HOURS OF OPERATION. THIS IS THE ONLY LUBRICATION THE CLAMSHELL NEEDS. SEE ILLUSTRATION NO.5 CLAMSHELL LUBRICATION CHART. USE GAA GREASE, ARTILLERY, AUTOMOTIVE.

****** CAUTION ******

USE ENOUGH GREASE. FAILURE TO DO SO MAY CAUSE COMPONENT AND EQUIPMENT FAILURE.

USE ENOUGH NEW GREASE TO COMPLETELY DISPLACE ALL THE OLD GREASE AND EMBEDDED ABRASIVES. IF THE PIN OR BUSHING WILL NOT ACCEPT GREASE, REMOVE AND CLEAN THE FITTING IN SOLVENT UNTIL GREASE FLOWS FREELY THROUGH IT. IF THE FITTING STILL WILL NOT ACCEPT GREASE, REMOVE THE PIN AND THOROUGHLY CLEAN THE GREASE PASSAGE IN SOLVENT. ALEMITE GREASE FITTINGS HAVE BEEN PROVIDED TO EASE MAINTENANCE. REPLACE BROKEN FITTINGS IMMEDIATELY AND REGREASE. IN DREDGING OPERATIONS, WHERE THE GREASE IS CONTINUALLY BEING WASHED OUT BY WATER, LUBRICATE MORE FREQUENTLY. LUBRICATE EVERY FOUR HOURS.

2. REMOVE ANY DIRT, MUD PACKED INSIDE OF THE BUCKET. MATERIAL PACKED IN THE BUCKET ADDS UNNECESSARY WEIGHT AND REDUCES THE PERFORMANCE OF THE CLAMSHELL.
3. INSPECT THE WIRE ROPE, AND BUCKET DAILY. PARTICULAR ATTENTION SHOULD BE GIVEN TO THE CONDITION OF THE WIRE ROPE (SEE "SAFETY PRECAUTIONS" FOR UNSAFE WIRE ROPE CONDITIONS), PINS, AND SOCKETS SUSPENDING THE BUCKET. INSPECT ALL PIVOT POINTS TO DETECT EXCESSIVE WEAR AND "SLOP" IN THE CONNECTION.

****** WARNING ******

OPERATING THE BUCKET WITH WORN CONNECTIONS PLACES UNDUE STRESS ON THE PINS, CAUSING UNEVEN WEAR AND EVENTUAL FAILURE, AND POSSIBLY RESULTING IN EQUIPMENT DAMAGE AND PERSONAL INJURY.

4. REPLACE WORN OR BROKEN PARTS IMMEDIATELY, DO NOT RETURN THE CLAMSHELL TO OPERATION. IF THIS INSPECTION DISCLOSES A CRACK OR ANY OTHER SIGN OF METAL FATIGUE, REPAIR BY A TRAINED WELDER BEFORE OPERATING.
5. REPLACE ANY BROKEN TOOTH.

****** WARNING ******

WEAR OSHA APPROVED HARD HATS, SAFETY GLASSES, SAFETY SHOES AND WORK GLOVES WHEN PERFORMING MAINTENANCE WORK.

CLAMSHELL LUBRICATION CHART

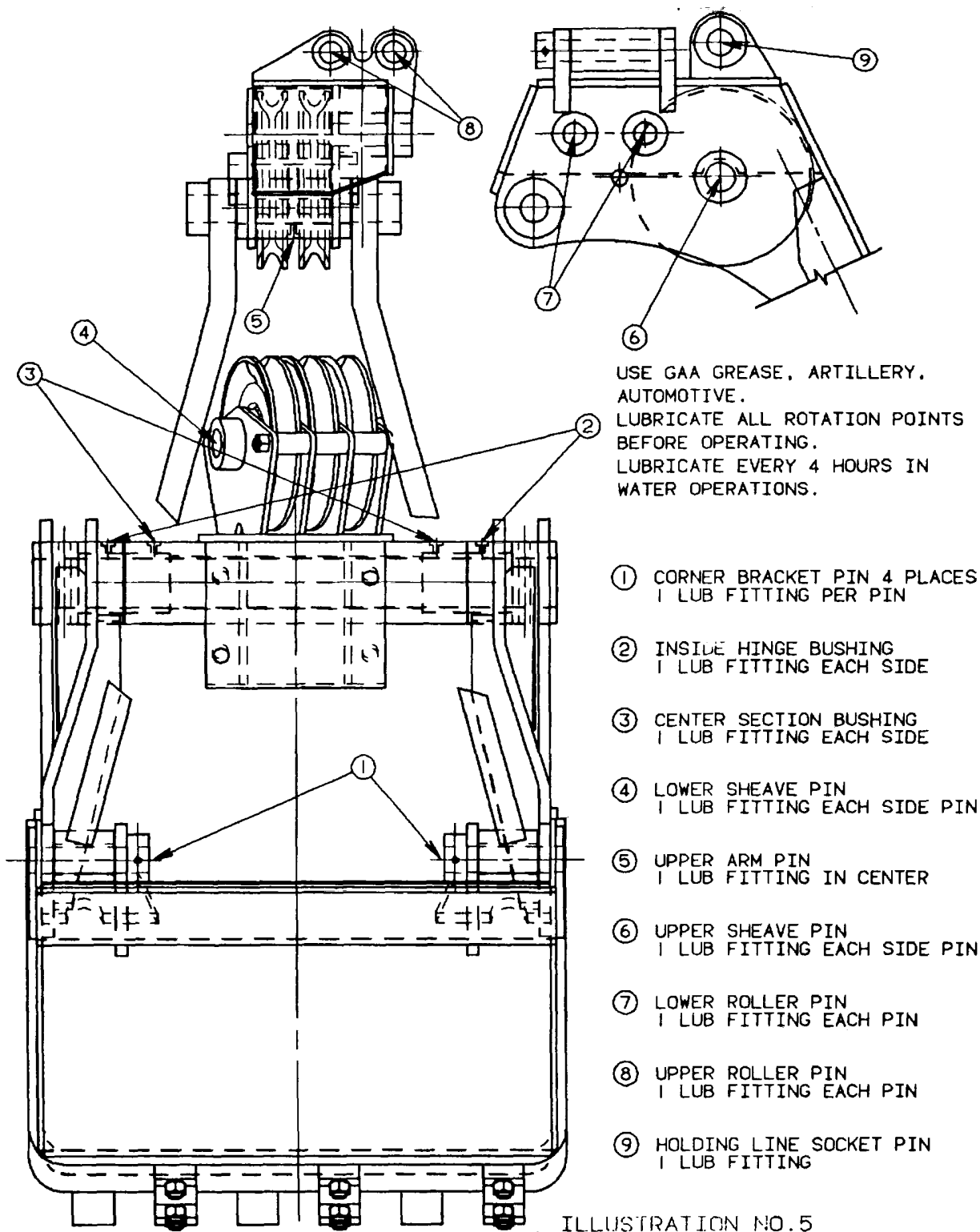

ILLUSTRATION NO. 5

SAFETY PRECAUTIONS

****** WARNING ******

WEAR OSHA APPROVED HARD HATS, SAFETY GLASSES, SAFETY SHOES AND WORK GLOVES WHEN PERFORMING MAINTENANCE WORK.

USE OSHA APPROVED WELDING HOODS, WORK GLOVES, SAFETY SHOES AND OTHER RECOMMENDED SAFETY ARTICLES WHEN WELDING. FAILURE TO DO SO WILL CREATE HAZARDOUS CONDITIONS FOR PERSONNEL.

DO NOT OPERATE BUCKET WITH WORN OR FRAYED WIRE ROPE. INSPECT DAILY AND REPLACE AS NECESSARY FOR SAFE OPERATION. REPLACE THE WIRE ROPE IF ANY OF THESE CONDITIONS EXIST:

- A. BROKEN WIRES: SIX RANDOMLY DISTRIBUTED BROKEN WIRES IN THE LENGTH OF ONE LAY, OR PITCH, OF THE ROPE
 OR
 THREE BROKEN WIRES IN ONE STRAND IN THE LENGTH OF ONE LAY, OR PITCH, OF THE ROPE.
- B. WORN WIRES: INDIVIDUAL OUTSIDE WIRES WORN TO TWO-THIRDS (2/3) OF ORIGINAL WIRE DIAMETER, ONE-THIRD (1/3) WORN AWAY. CHECK INDIVIDUAL WIRE AT HOIST SOCKET DEAD END. WIRE SIZE WILL VARY WITH WIRE ROPE MANUFACTURERS.
- C. DAMAGED WIRES: KINKED, CRUSHED OR BIRDCAGED WIRES. EVIDENCE OF HEAT DAMAGE FROM ANY CAUSE.
- D. DECREASE IN WIRE ROPE DIAMETER:
 1/64" FOR NOMINAL DIAMETERS TO 5/16"
 1/32" FOR NOMINAL DIAMETERS OF 3/8 AND 1/2"
 3/64" FOR NOMINAL DIAMETERS OF 9/16, 5/8 AND 3/4"

NOTE: MEASURE ROPE OVER STRANDS NOT ACROSS FLATS.

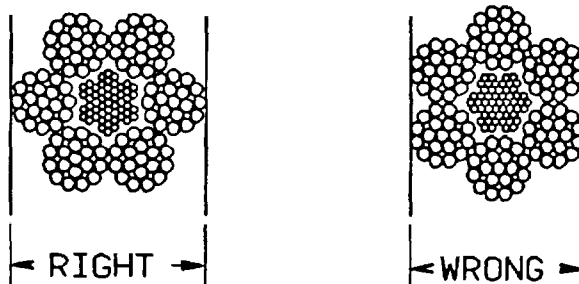

****** WARNINGS ******

DO NOT POSITION THE BUCKET, EMPTY OR LOADED OVER ANY PERSON, FALLING BUCKETS CAN CAUSE INJURY OR DEATH.

DO NOT LET ANYONE RIDE IN THE BUCKET. THE BUCKET IS NOT DESIGNED TO BE AN ELEVATOR. ANY SUDDEN OPENING CAN CAUSE INJURY OR DEATH.

DO NOT LET ANYONE GET BETWEEN THE JAWS OF THE BUCKET, NOT EVEN IF THE BUCKET IS LYING OPEN ON THE GROUND, SUDDEN CLOSING CAN CAUSE INJURY OR DEATH.

DO NOT THROW OR CAST THE BUCKET AS THIS IMPOSES LOADS ON THE CRANE NOT COVERED BY CAPACITY TABLES AND MAY TIP CRANE CAUSING PERSONNEL INJURY OR EQUIPMENT DAMAGE.

DO NOT ALTER SHEAVE GUARDS. PROPER GUARDING IS PLACED AROUND THE SHEAVE TO KEEP THE CABLES WITHIN THE SHEAVE GROOVES. MAINTAIN GUARD SO THE CABLE WILL NOT JUMP THE SHEAVES, BE PINCHED OR CUT, THUS REDUCING THE SAFETY FACTOR.

DAILY INSPECT THE PINS AND OTHER PARTS SUSPENDING THE BUCKET. BE SURE THEY DO NOT BECOME UNDULY WORN AND CAN NO LONGER SUSPEND THE LOAD OF THE BUCKET.

REPAIR BUCKET IMMEDIATELY IF DAMAGE IS FOUND. FAILURE TO DO SO MAY CAUSE INJURY OR DEATH.

DO NOT OPERATE THE BUCKET OUTSIDE THE RECOMMENDED CAPACITIES OF YOUR CRANE EQUIPMENT. KNOW THE WEIGHT OF THE BUCKET USE CRANE LOAD CHART TO CALCULATE THE EXPECTED LOADS PICKED UP. OVERLOADING MAY TIP CRANE CAUSING PERSONNEL INJURY AND EQUIPMENT DAMAGE.

****** WARNING ******

BEFORE OPERATION ENSURE ALL NUTS, BOLTS AND COTTER PINS ARE INSTALLED AND SERVICEABLE, USING CORRECT SIZE WRENCHES TO SECURE ALL BOLTS AND NUTS. FAILURE TO DO SO WILL CAUSE INJURY TO PERSONNEL AND DAMAGE TO EQUIPMENT.

****** WARNING ******

SUPERVISOR/OPERATOR WILL ENSURE PERSONNEL NOT INVOLVED WITH OPERATIONS REMAIN AT LEAST 50 FEET FROM EQUIPMENT. FAILURE TO DO THIS MAY CAUSE PERSONNEL INJURY.

c/(d blank)

SOCKET AND LINK MAINTENANCE****** WARNING ******

WEAR OSHA APPROVED HARD HATS, SAFETY GLASSES, SAFETY SHOES AND WORK GLOVES WHEN PERFORMING MAINTENANCE WORK.

INSPECT THE HOLDING LINE SOCKET, LINK AND PINS FOR WEAR EVERY 600 OPERATING HOURS UNDER NORMAL OPERATION. OBSERVE ANY UNUSUAL LOOSENESS AT THE SOCKET AND HOLDING LINE PIN WHEN THE BUCKET IS LIFTED BY THE HOLDING LINE ALONE. REPLACE THE SOCKET, LINK, AND PINS WHEN WEAR AT THE PIN AREAS EQUAL OR EXCEED 25% OF THE PIN AREA OR SOCKET OR LINK HOLE IS DISTORTED, 1/8" OR MORE.

****** WARNING ******

USE OSHA APPROVED WELDING HOODS, WORK GLOVES, SAFETY SHOES AND OTHER RECOMMENDED SAFETY ARTICLES WHEN WELDING. FAILURE TO DO SO WILL CREATE HAZARDOUS CONDITIONS FOR PERSONNEL.

REBUILD THE HOLE OR REPLACE COMPONENT WHEN WEAR IN THE HOLDING LINE PIN LUGS ARE INCREASED 25% GREATER THAN THE PIN DIAMETER OR ARE DISTORTED. WHEN REBUILDING THE HEAD LUGS PROVIDE PROPER ALIGNMENT OF THE HOLDING LINE PIN.

WELD HOLES USING E7016 ROD TO 1 1/2" DIAMETER. BORE HOLES TO 1 21/32 DIAMETER AFTER WELDING.

****** CAUTION ******

A COCKED HOLDING LINE PIN WILL RESULT IN UNUSUAL LINK WEAR AND POSSIBLE FAILURE.

FIND PROCEDURES FOR REMOVAL/REPLACEMENT ON PAGES 33 AND 34 OF THE CLAMSHELL DISASSEMBLY SECTION.

ROLLER MAINTENANCE

**** WARNING ****

WEAR OSHA APPROVED HARD HATS, SAFETY GLASSES, SAFETY SHOES AND WORK GLOVES WHEN PERFORMING MAINTENANCE WORK.

INSURE COTTER PINS ARE IN PLACE EACH TIME THE ROLLERS ARE LUBRICATED. THE ROLLERS MUST TURN FREELY OR THE ROPE AND ROLLER LIFE WILL BE CONSIDERABLY SHORTENED.

CLEAR OBSTRUCTIONS FROM STICKING ROLLERS AND CLEAN ANY DIRT OR CORROSION FROM THE ROLLER ASSEMBLY. CLEAN CLOGGED OR RESTRICTED GREASE HOLES IN THE ROLLER PINS AS REQUIRED.

ROLLER INSPECTION

INSPECT THE ROLLERS, PINS (UPPER/LOWER) EVERY 600 HOURS OF OPERATION. USE A PRY BAR TO MOVE THE ROLLERS APART. SHOULD THE ASSEMBLY SHOW EXCESSIVE WEAR, (MOVEMENT OF 3/8 INCHES OR MORE) REMOVE THE PIN. MEASURE BOTH THE PIN AND ROLLER TO DETERMINE THE EXTENT OF WEAR. REPLACE PINS WHEN THEY ARE WORN 25% OR MORE OF THE PIN AREA. REPLACE THE ROLLERS WHEN THEY DO NOT TURN FREE AND TRUE OR WHEN THE INSIDE DIAMETER IS 1 21/32 OR MORE OR THE OUTSIDE DIAMETER IS GROOVED 50% OF THE ROPE DIAMETER IN ANY AREA.

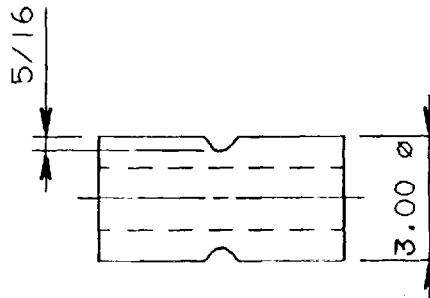

FIND PROCEDURES FOR REMOVAL/REPLACEMENT ON PAGE 35 OF THE CLAMSHELL DISASSEMBLY SECTION.

UPPER ARM PIN MAINTENANCE

****** WARNING ******

WEAR OSHA APPROVED HARD HATS, SAFETY GLASSES, SAFETY SHOES AND WORK GLOVES WHEN PERFORMING MAINTENANCE WORK.

INSURE THE COTTER PINS ARE IN PLACE EACH TIME YOU GREASE THE ARM PIN.

***** CAUTION *****

LOSS OF A COTTER PIN WILL CAUSE THE ENTIRE ASSEMBLY TO LOOSEN. RAPID WEAR AND POSSIBLE FAILURE OF THE UNIT WILL RESULT.

ROTATE THE PIN 180- EVERY 600 HOURS OF OPERATION.

SEMI-ANNUALLY CHECK THE HEAD FOR WORN STEEL BUSHINGS INSIDE THE HEAD TUBE. REPLACE BUSHING WHEN INSIDE DIAMETER IS 1 15/16 OR MORE. REPLACE THE ARM PIN WHEN REPLACING THE BUSHINGS.

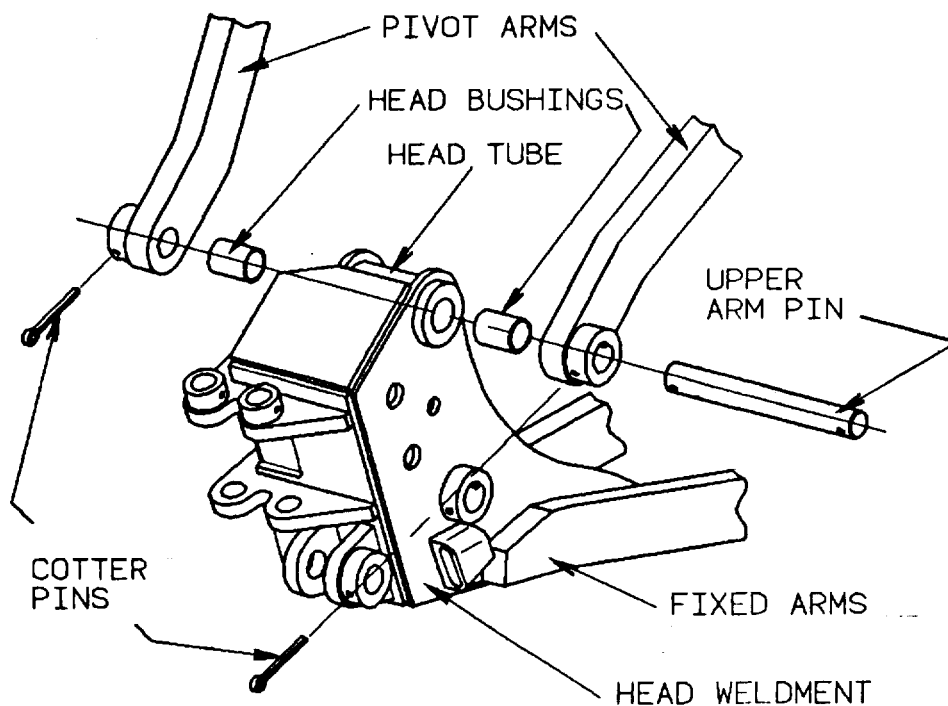

FIND PROCEDURES FOR REMOVAL/REPLACEMENT ON PAGES 31 AND 32 OF THE CLAMSHELL DISASSEMBLY SECTION.

UPPER ARM PIN MAINTENANCE

UPPER ARM PIN ROTATION

1. LAY CLAMSHELL DOWN ON FIXED ARM, OUTSIDE HINGE SIDE.

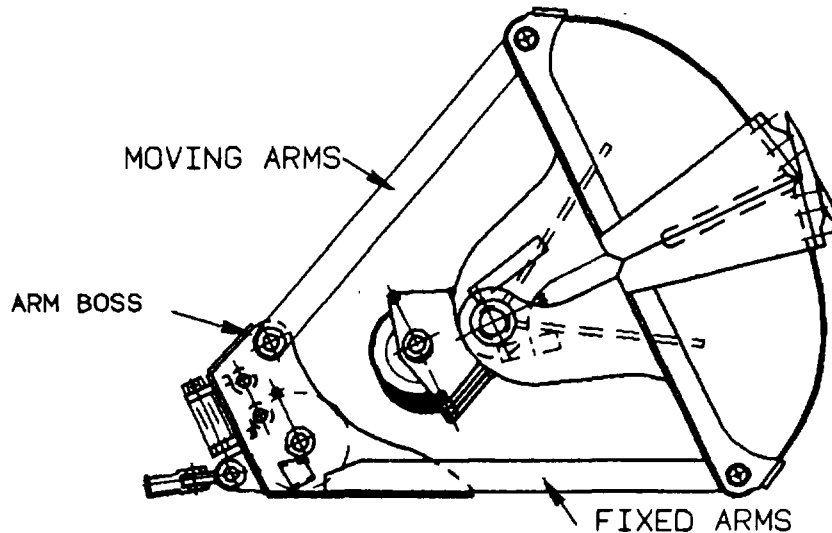

2. REMOVE COTTER PINS FROM ARM BOSS.
3. CAREFULLY DRIVE PIN OUT ONE ARM BOSS 1 ¼.
4. INSERT PUNCH OR OTHER SUITABLE TOOL IN ARM PIN CROSS HOLE AND ROTATE PIN 180.

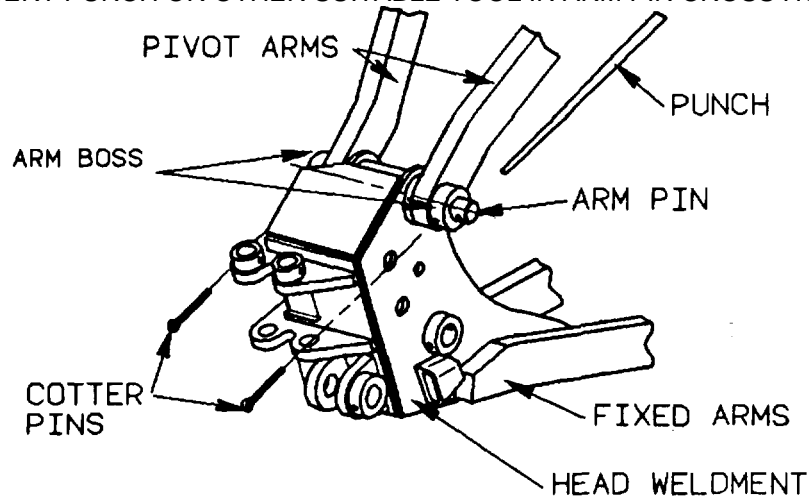

5. ALIGN HOLES IN PIN WITH HOLES IN ARM BOSSES AND DRIVE PIN BACK INTO PLACE. INSTALL NEW 7/16 X 4 1/2 COTTER PINS.

FIND PROCEDURES FOR REMOVAL/REPLACEMENT ON PAGE 32 OF THE CLAMSHELL DISASSEMBLY SECTION.

ARM BAR MAINTENANCE

****** WARNING ******

WEAR OSHA APPROVED HARD HATS, SAFETY GLASSES, SAFETY SHOES AND WORK GLOVES WHEN PERFORMING MAINTENANCE WORK, USE OSHA APPROVED WELDING HOODS, WORK GLOVES, SAFETY SHOES AND OTHER RECOMMENDED SAFETY ARTICLES WHEN WELDING. FAILURE TO DO SO WILL CREATE HAZARDOUS CONDITIONS FOR PERSONNEL.

INSPECT ARM BARS AT EACH LUBRICATION. REPLACE BENT OR DISTORTED ARMS. REPAIR NICKS AND MINOR GOUGES BY WELDING WITH E-7018 OR EQUIVALENT LOW HYDROGEN ROD. GRIND THE REPAIRED AREA TO ORIGINAL SHAPE AFTER WELDING.

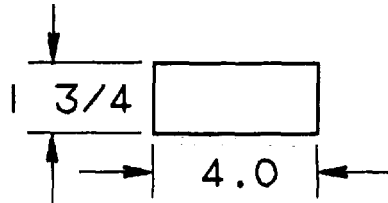

ARM BAR ORIGINAL SHAPE

CYCLE THE BUCKET IN THE AIR-AND OBSERVE ANY UNUSUAL MOVEMENT OF THE ARMS IN THE CORNER BRACKETS. REPLACE LOWER ARM BUSHING IF EXCESSIVE MOVEMENT IS OBSERVED. REPLACE BRACKET PIN IF LOWER ARM BUSHING IS REPLACED.

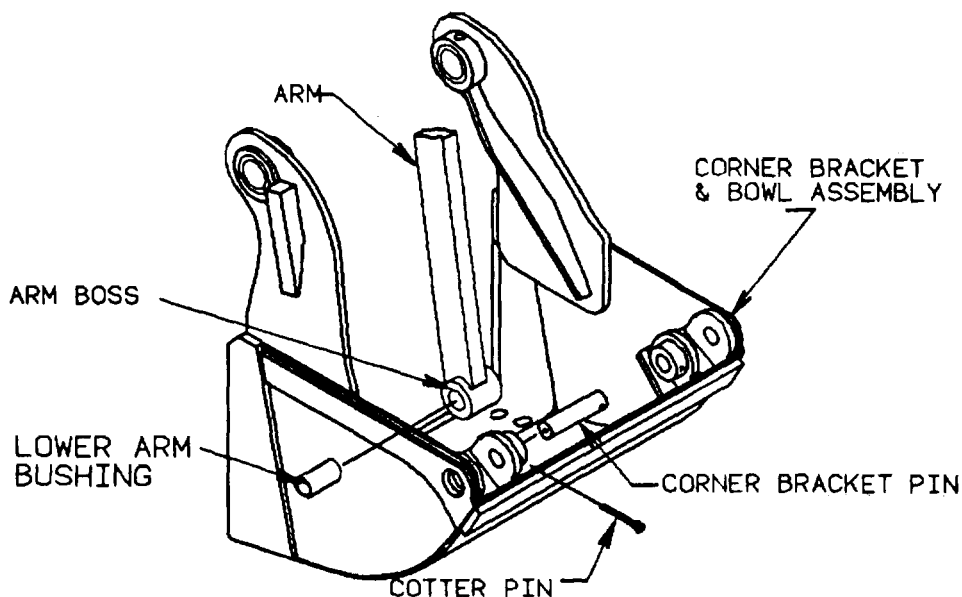

FIND PROCEDURES FOR REMOVAL/REPLACEMENT ON PAGES 31, 32 AND 37 OF THE CLAMSHELL DISASSEMBLY SECTION.

CORNER BRACKET MAINTENANCE

****** WARNING .*****

WEAR OSHA APPROVED HARD HATS, SAFETY GLASSES, SAFETY SHOES AND WORK GLOVES WHEN PERFORMING-MAINTENANCE WORK.

****** CAUTION ******

COTTER PINS MUST BE IN PLACE EACH TIME THE BRACKET PINS ARE LUBRICATED.

****** CAUTION ******

LOSS OF THE COTTER PIN WILL CAUSE THE ENTIRE ASSEMBLY TO LOOSEN RESULTING IN EXCESSIVE WEAR AND POSSIBLE FAILURE AND DAMAGE TO EQUIPMENT.

INSPECT AND ROTATE THE BRACKET PINS EVERY 600 HOURS OF NORMAL OPERATION. INSPECT THE INSIDE OF THE BRACKET EARS FOR WEAR AND EXCESSIVE SIDE PLAY. REPLACE PINS WHEN THEY ARE WORN 25% OR MORE OF THE PIN AREA. REPLACE THE LOWER ARM BUSHINGS WHEN PINS ARE REPLACED.

****** WARNING ******

USE OSHA APPROVED WELDING HOODS, WORK GLOVES, SAFETY SHOES AND OTHER RECOMMENDED SAFETY ARTICLES WHEN WELDING. FAILURE TO DO SO WILL CREATE HAZARDOUS CONDITIONS FOR PERSONNEL.

THE LOWER ARM BOSS MUST ROTATE FREELY IN THE CORNER BRACKET. REMOVE ANY OBSTRUCTION AND CLEAN DIRT AND CORROSION FROM THE ASSEMBLY. CLEAN ANY CLOGGED OR RESTRICTED BRACKET PIN GREASE HOLES AS REQUIRED. REBUILD WORN AREAS OF THE BRACKET EARS BY WELDING WITH E-7018 OR EQUIVALENT LOW HYDROGEN ROD. GRIND THE REPAIRED AREA AFTER WELDING TO ORIGINAL SHAPE.

REBUILD OR REPLACE CORNER BRACKET IF PIN HOLE IS DISTORTED 1/8" OR MORE. WELD HOLES USING E-7018 ROD TO 1 5/8" DIA- METER. BORE HOLES TO 1 23/32 AFTER WELDING.

FIND PROCEDURES FOR REMOVAL/REPLACEMENT ON PAGE 31 OF THE CLAMSHELL DISASSEMBLY SECTION.

CORNER BRACKET MAINTENANCE

****** WARNING ******

WEAR OSHA APPROVED HARD HATS, SAFETY GLASSES, SAFETY SHOES AND WORK GLOVES WHEN PERFORMING MAINTENANCE WORK.

BRACKET PIN ROTATION

1. STAND OPEN CLAMSHELL ON TEETH, MAINTAINING TENSION ON HOLDING LINE AND SLACK IN CLOSING LINE.

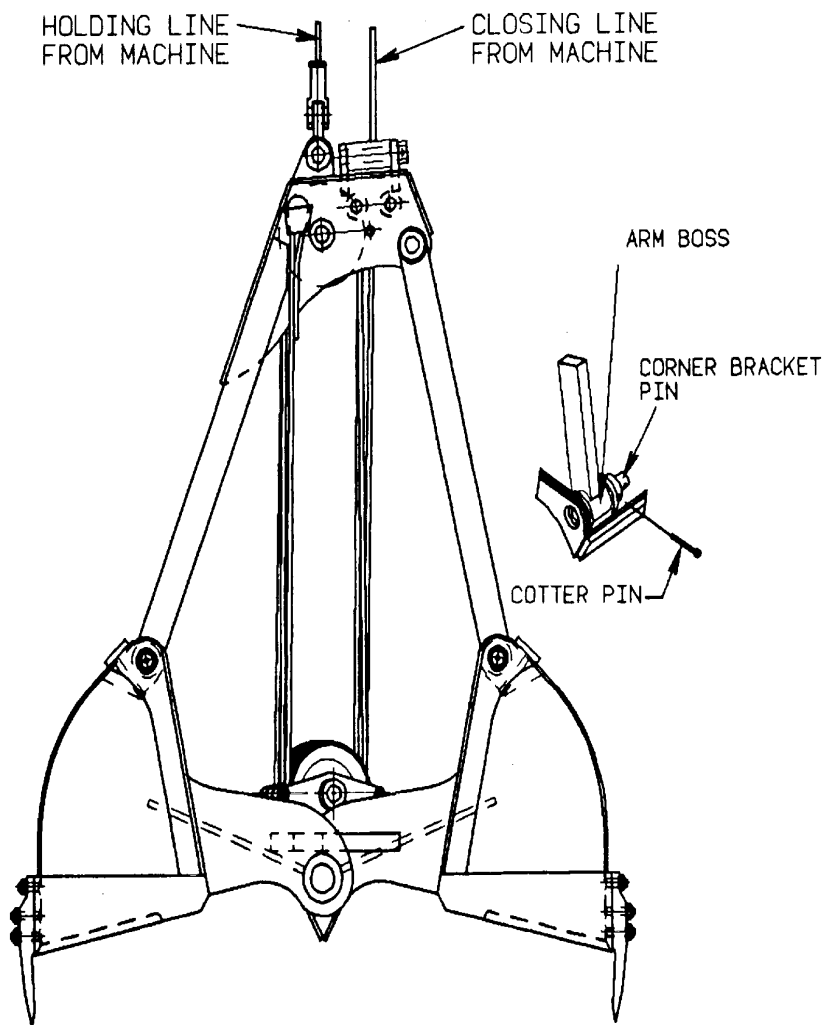

2. REMOVE COTTER PIN FROM BUCKET USING DRIFT AND HAMMER. DISCARD COTTER PIN.
3. CAREFULLY DRIVE BRACKET PIN TO INSIDE THE BUCKET TO EXPOSE THE CROSS HOLE IN PIN USING BACKING OUT PUNCH AND HAMMER.
4. ROTATE PIN 180 DEGREES USING THE CROSS HOLE AND PUNCH.
5. ALIGN CROSSHOLE IN PIN WITH HOLES IN THE BRACKET AND DRIVE PIN INTO PLACE.
6. INSTALL NEW 7/16 X 4 1/2 COTTER PIN.
7. REPEAT STEPS 2 THROUGH 6 FOR REMAINING BRACKET PINS.

LOWER BLOCK & MAIN SHAFT MAINTENANCE

***** WARNING *****

WEAR OSHA APPROVED HARD HATS, SAFETY GLASSES, SAFETY SHOES AND WORK GLOVES WHEN PERFORMING MAINTENANCE WORK.

CHECK THE MAIN SHAFT LOCKING BOLTS FOR TIGHTNESS AT LUBRICATION. NO TURNING OF THE MAINSHAFT WILL BE ALLOWED.

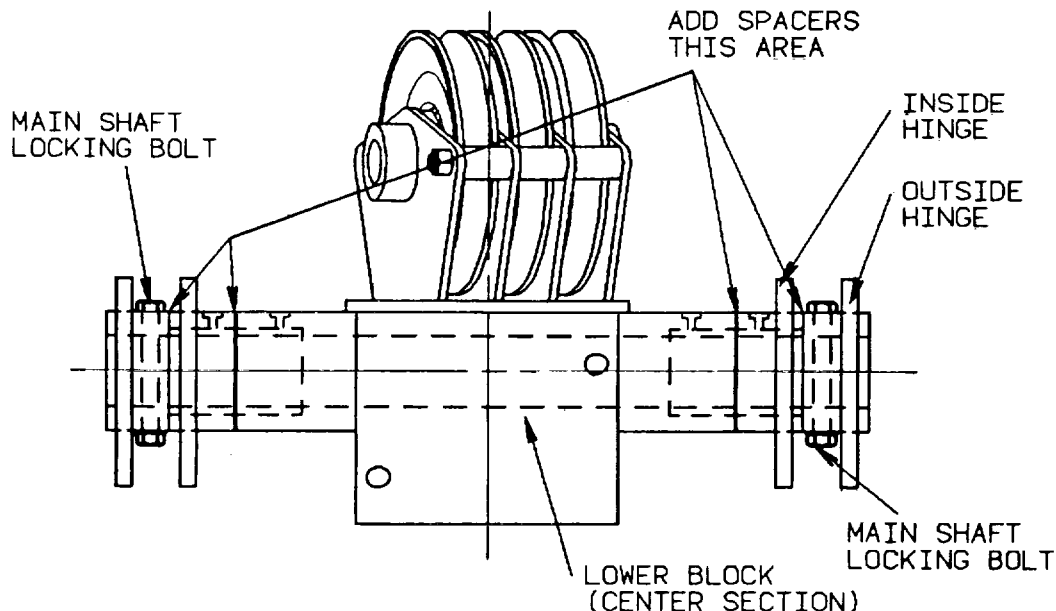

BOTH INSIDE HINGES SHOULD TURN FREELY BETWEEN THE LOWER BLOCK AND OUTSIDE HINGES WITH MINIMAL (1/8") SIDE PLAY. IF THE HINGE DOES NOT ROTATE FREELY, REMOVE ANY OBSTRUCTION AND CLEAN ANY DIRT OR CORROSION FROM THE ASSEMBLY. CHECK THE GREASE PATHS IN THE LOWER BLOCK AND INSIDE HINGES FOR RESTRICTIONS OR CLOGGED HOLES.

NORMAL WEAR WILL BE EVIDENT BETWEEN THE MAIN SHAFT, LOWER BLOCK BUSHING AND BETWEEN THE HINGES AND LOWER BLOCK. ROTATE THE MAIN SHAFT EVERY 600 HOURS OF NORMAL OPERATION. THIS PROCEDURE WILL EXTEND THE SERVICE LIFE OF THE SHAFT.

REMOVE THE MAIN SHAFT EVERY 1000 HOURS OF NORMAL OPERATION AND INSPECT FOR WEAR. MEASURE MAIN SHAFT, LOWER BLOCK AND INSIDE HINGE BUSHINGS TO DETERMINE IF THE EXTENT OF WEAR IS 25% OR GREATER.

ADD SPACERS OF EQUAL THICKNESS TO REMEDY WEAR BETWEEN THE INSIDE HINGES, LOWER BLOCK AND OUTSIDE HINGES TO REDUCE SIDE CLEARANCE.

****** CAUTION *****

DO NOT SHIFT THE LOWER BLOCK TO ONE SIDE. THIS CONDITION WILL RESULT IN ROPE AND SHEAVE WEAR.

LOWER BLOCK & MAIN SHAFT MAINTENANCE

MAINSHAFT ROTATION

NOTE

ALL COMMON HARDWARE MUST BE ON HAND.

1. STAND OPEN BUCKET ON TEETH. (1) ALLOW SLACK IN HOLDING LINE.

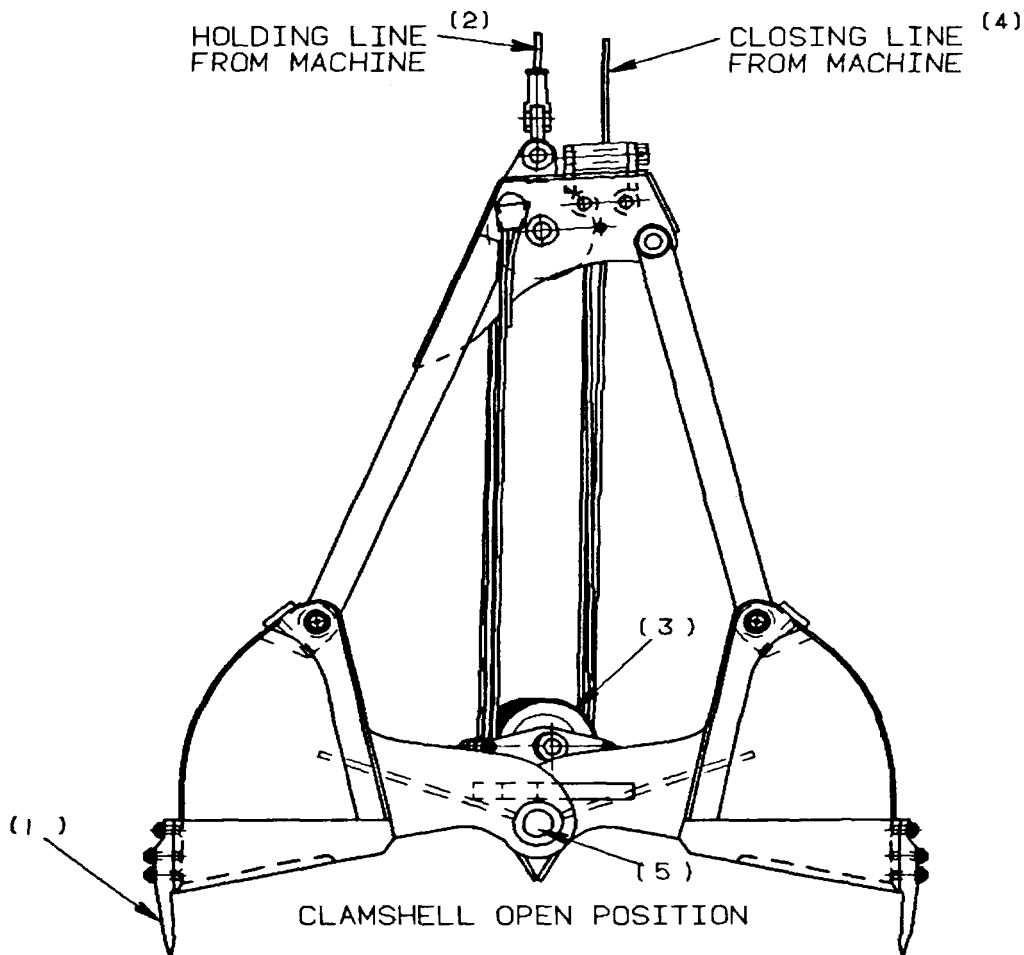

3. USE OXY-ACETYLENE TORCH BURN OFF LOCK BOLT AT OUTSIDE HINGE BOSS.(SEE ILLUSTRATION ON PAGE 23)
4. DRIVE BOLT THROUGH MAIN SHAFT(5) AND HINGE BOSS USING BACK OUT PUNCH AND HAMMER.
5. REPEAT STEPS 3 AND 4 FOR OTHER BOLT.

LOWER BLOCK & MAIN SHAFT MAINTANENCE

6. DRIVE MAIN SHAFT(1) THROUGH HINGES(2+3) AND LOWER BLOCK(8) UNTIL THE LOCK BOLT HOLE(7) IS EXPOSED.

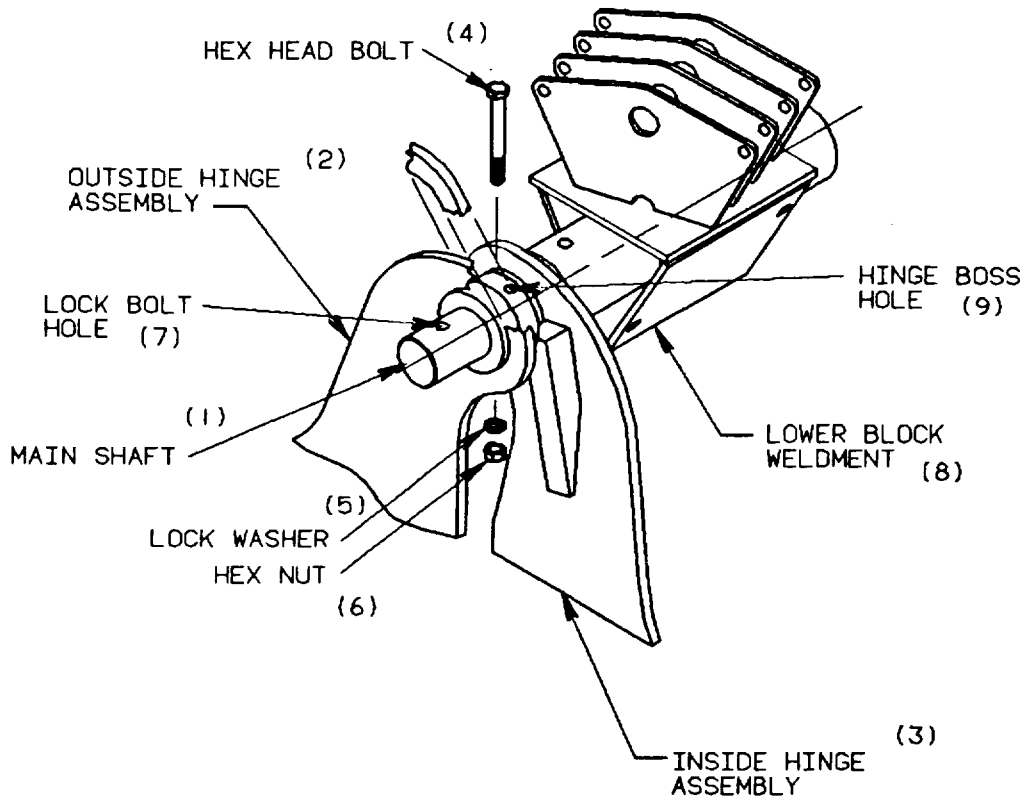

7. ROTATE THE MAIN SHAFT(1) 180" USING THE LOCK BOLT HOLE(7) AND A PRYING AND ALIGNING BAR.
8. ALIGN THE LOCK BOLT HOLE(7) IN THE MAIN SHAFT(1) WITH THE HINGE BOSS HOLE(9).
9. USE HAMMER AND DRIVE MAIN SHAFT(1) INTO HINGE ASSEMBLY(2+3).
10. INSTALL TWO (2) NEW 3/4-O1UNC X 6 1/2" BOLTS(4) WITH NUTS(5) AND LOCKWASHERS(6) USING 1 1/8 INCH WRENCH AND SOCKET.
11. TIGHTEN NUTS TO APPROXIMATELY 375 FT. LBS.

FIND PROCEDURES FOR REMOVAL/REPLACEMENT ON PAGE 39 OF THE CLAMSHELL DISASSEMBLY SECTION.

CLOSING SHEAVE MAINTENANCE

INSURE THE COTTER PINS ARE IN PLACE EACH TIME THE CLOSING SHEAVE ASSEMBLIES ARE LUBRICATED.

*** CAUTION ***

THE SHEAVE PIN MUST NOT BE ALLOWED TO LOOSEN IN THE SHEAVE PLATES. PIN MOVEMENT WILL CAUSE UNDUE WEAR OF THE PIN HOLE, INCREASE MAINTENANCE TIME AND POSSIBLE BUCKET FAILURE.

*** CAUTION ***

THE CLOSING SHEAVES MUST TURN FREELY OR REDUCED ROPE AND SHEAVE LIFE WILL RESULT.

CHECK STICKING SHEAVES FOR OBSTRUCTIONS, CLEAN DIRT AND CORROSION FROM THE ASSEMBLIES. INSPECT AND CLEAN THE GREASE PATHS IN THE SHEAVES AND PINS.

CHECK THE FIRST SHEAVE IN THE LOWER BLOCK THE ROPE PASSES AROUND BY LIFTING WITH A PRY BAR. MOVEMENT OF 1/8" OR MORE IS EXCESSIVE.

NOTE

EXCESSIVE WEAR HERE IS AN INDICATION THAT THE OTHER SHEAVE BUSHINGS AND PIN ARE ALSO WORN.

IF WEAR APPEARS EXCESSIVE, DISASSEMBLE SHEAVE ASSEMBLIES TO DETERMINE THE EXTENT OF WEAR. REPLACE SHEAVE BUSHINGS WITH AN INSIDE DIAMETER OF 2 1/16" OR MORE. REPLACE -PINS THAT ARE WORN 25 % OR MORE OF THE PIN AREA.

**** CAUTION ****

REPLACE WORN SHEAVES. OUTSIDE RIMS OF THE ROPE GROOVE WORN TO A KNIFE EDGE MAY SLICE AND WEAKEN THE ROPE. WORN ROPE GROOVES CAUSE THE ROPE TO FLATTEN AND BECOME WEAKENED. FAILURE OF COMPONENTS CAN OCCUR.

NOTE

SHEAVE PLATES IN THE HEAD AND LOWER BLOCK ALSO WEAR. THE SHEAVE THEN SHIFTS FROM SIDE TO SIDE RESULTING IN SHEAVE PLATE, SHEAVE, PIN, BUSHING, AND ROPE WEAR.

REBUILD SHEAVE PLATES, REPLACE SHEAVE PLATES OR REPLACE ENTIRE ASSEMBLY.

CLOSING SHEAVE MAINTENANCE

NOTE

THE ROPE GUIDE BOLT IN THE HEAD WELDMENT AND THE CABLE GUIDE SPOOLS IN THE LOWER BLOCK WILL WEAR BECAUSE THEY CONTAIN THE ROPE PASSING AROUND THE SHEAVE.

INSPECT ROPE GUIDE BOLT IN HEAD WELDMENT AND CABLE GUIDE SPOOL IN THE LOWER BLOCK. REPLACE IF GROOVED 3/16" OR MORE.

FIND PROCEDURES FOR REMOVAL/REPLACEMENT ON PAGES 36 AND 38 OF THE COMPONENT DISASSEMBLY SECTION.

LIP AND BOWL MAINTENANCE

****** WARNING *****

WEAR OSHA APPROVED HARD HATS, SAFETY GLASSES, SAFETY SHOES AND WORK GLOVES WHEN PERFORMING MAINTENANCE WORK.

USE OSHA APPROVED WELDING HOODS, WORK GLOVES, SAFETY SHOES AND OTHER RECOMMENDED SAFETY ARTICLES WHEN WELDING. FAILURE TO DO SO WILL CREATE HAZARDOUS CONDITIONS FOR PERSONNEL.

OPERATE THE NEW CLAMSHELL BUCKET THREE TO FOUR WEEKS TO ALLOW ANY LIP WEAR PATTERNS TO DEVELOP AND THE FABRICATION STRESSES TO BE RELIEVED. HARDFACING WITH MANGALLOY FLOW-MANG WELDING ELECTRODES OR EQUIVALENT MAY BE USED IN AREAS

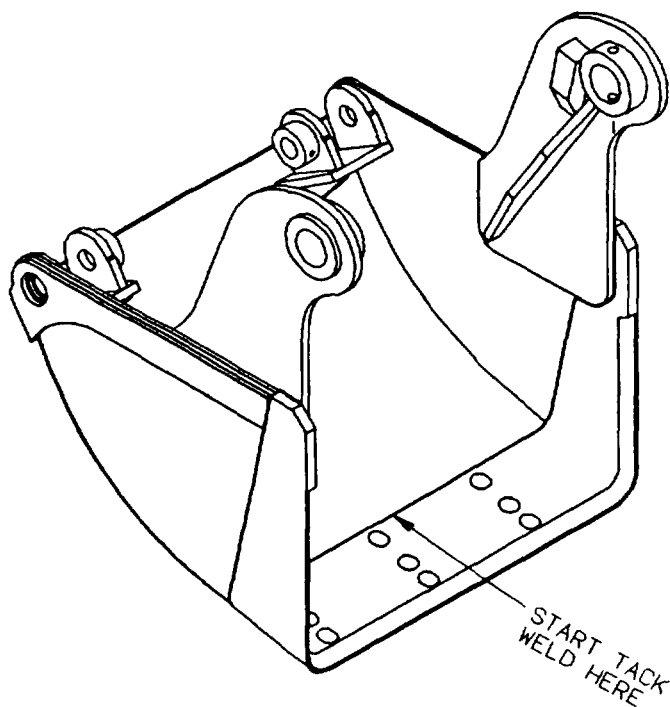

LIP WEAR NORMALLY OCCURS INSIDE AND OUTSIDE NEAR THE LEADING EDGE. HARDFACING ON THE LEADING EDGE OF NEW LIPS OR BUILT UP WORN EDGES BEYOND THE ORIGINAL CONTOUR DOES NOT PERMIT THE BOWLS TO CLOSE PROPERLY.

INSPECT THE LIPS AND BOWLS EVERY 600 HOURS UNDER NORMAL OPERATION FOR UNUSUAL WEAR, DENTS, CRACKS, TEARS, OR PUNCTURES. REPLACE THE COMPONENT OR COMPLETE ASSEMBLY IF WEAR EXCEEDS 25% OF COMPONENT THICKNESS OR STRUCTURAL DAMAGE IS FOUND.

LIP AND BOWL MAINTENANCE

LIP REMOVAL/REPLACEMENT

****** WARNING ******

KEEP ALL PARTS OF BODY FROM UNDER EQUIPMENT. FAILURE TO DO SO MAY CAUSE INJURY OR DEATH.

1. CUT THROUGH BACK AND SIDE PLATES ALONG THE LIP TO WITHIN 8" OF THE TOP OF THE BOWL USING AIR ARC OR OXY-ACETYLENE TORCH. EDGE FROM OUTSIDE
2. AIR ARC FROM OUTSIDE THE REMAINING 8" ON EACH SIDE BUT ONLY TO DEPTH OF HINGE PLATE.
3. AIR ARC WELD ONLY ON THE TOP OF BOWL BETWEEN HINGE AND LIPS ONLY.
4. AIR ARC ONLY THE WELD ON INSIDE OF LIPS ALONG FRONT AND BOTTOM EDGES OF HINGES.
5. REMOVE LIP.

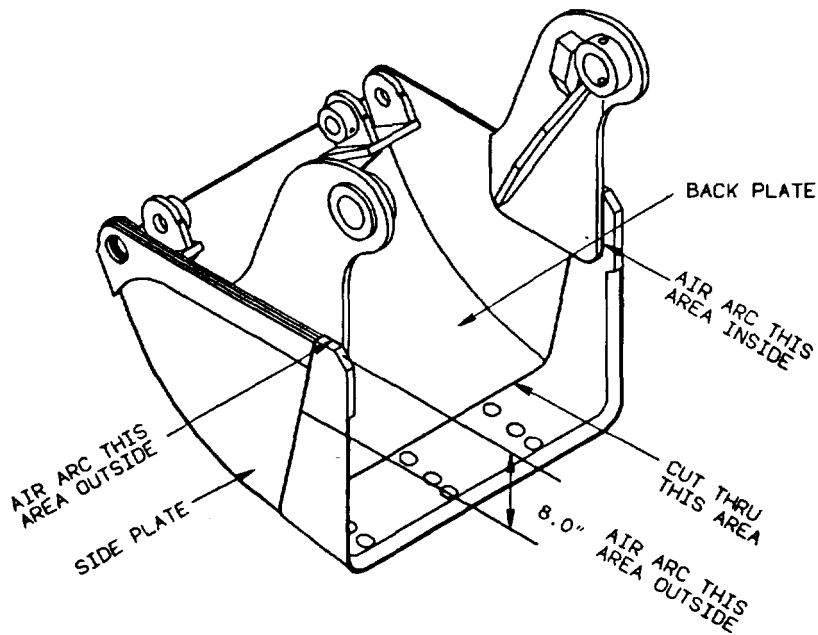

**LIP AND BOWL MAINTENANCE
LIP REMOVAL/REPLACEMENT**

6. REPAIR ANY GOUGES ON HINGES BY WELDING AND GRINDING.
7. REMOVE ANY SLAG BY CHIPPING OR GRINDING.
8. FIT NEW LIP TO BOWL AND TACK WELD ON INSIDE TO THE BOTTOM PLATE START AT THE CENTER AND WORKING OUTWARD ON 9" CENTERS.
9. TACK WELD OUTSIDE OF LIP TO SIDE PLATES AT CENTER AND TOP.
10. TACK WELD INSIDE OF LIP TO HINGE AT FRONT OF HINGE.
11. START AT OUTSIDE CENTER ON LIP BOTTOM AND APPLY 3/8 FILLET WELD OF E-7018 OR EQUIVALENT LOW HYDROGEN ROD BY THE STRINGER METHOD ON ALTERNATE SIDES OF THE CENTER TO THE TOP OF THE BOWL.
12. APPLY BACK UP BEAD TO INSIDE, START AT CENTER AND WORK OUTWARD AND UP TO THE HINGE.
13. APPLY 3/8 FILLET TO HINGE INSIDE AND ON OUTSIDE ALONG THE TOP EDGE OF LIP.

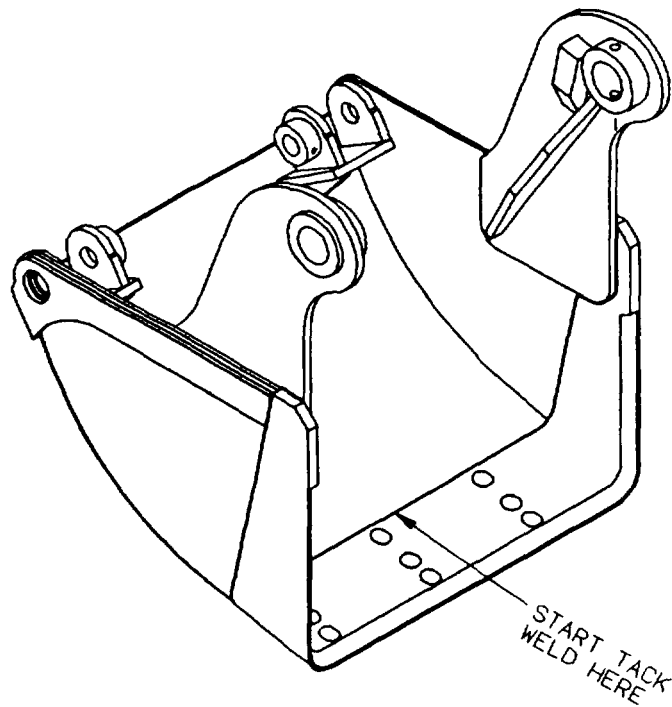

TOOTH MAINTENANCE

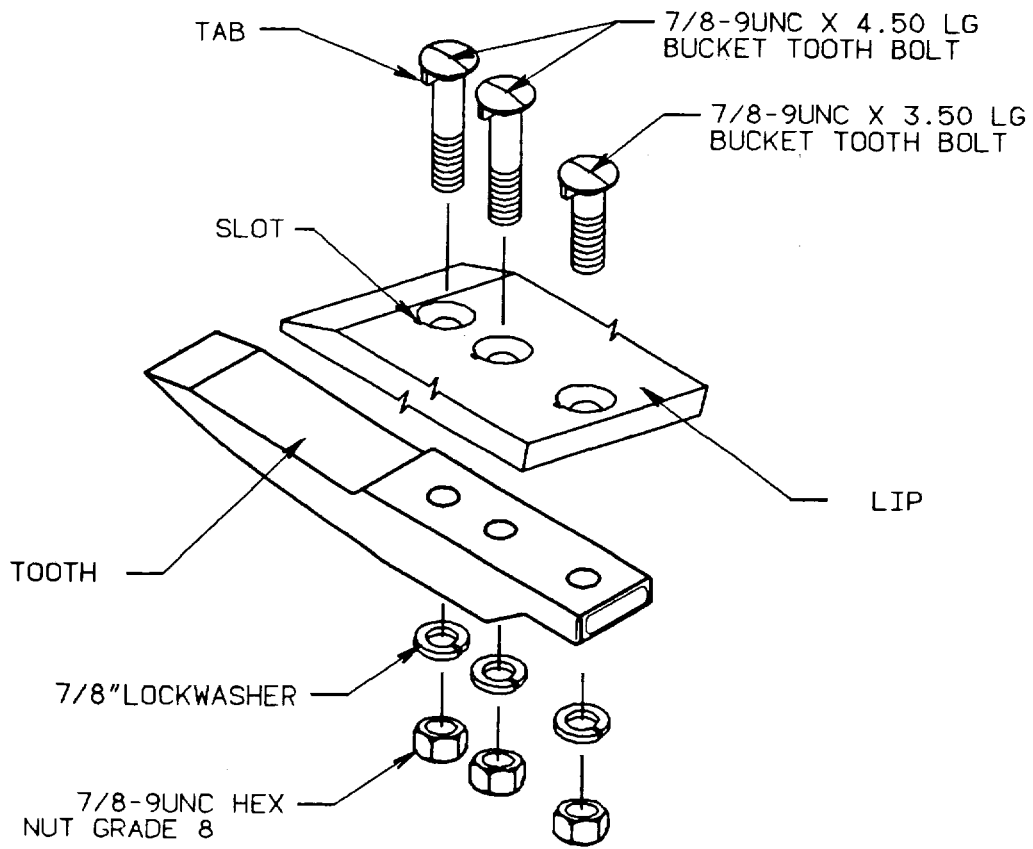

TOOTH MAINTENANCE

****** WARNING ******

WEAR OSHA APPROVED HARD HATS, SAFETY GLASSES, SAFETY SHOES AND WORK GLOVES WHEN PERFORMING MAINTENANCE WORK.

KEEP THE BOLTS HOLDING THE TEETH ON THE LIP TIGHT.

****** CAUTION *****

LOOSE BOLTS MOVE AND ENLARGE THE HOLES CAUSING BOLT FAILURE.

REPLACE TEETH WHEN WORN BACK 2" OR IF PART OF THE TIP IS BROKEN. MINIMUM TOOTH LENGTH 15".

TOOTH REMOVAL/REPLACEMENT

NOTE

ALL COMMON HARDWARE MUST BE ON HAND PRIOR TO PROCEDURE.

TOOTH REMOVAL:

1. LAY CLAMSHELL ON ITS SIDE WITH THE BOWLS OPEN.
2. BURN NUTS OFF THE BUCKET TOOTH BOLTS USING AN OXYACETYLENE TORCH.
3. DRIVE THE REMAINDER OF THE BOLT(S) OUT OF TOOTH AND LIP USING A 3/4" PUNCH AND HAMMER. DISCARD USED TOOTH, NUTS, BOLTS, AND LOCKWASHERS.

TOOTH REPLACEMENT:

1. INSTALL 2 (TWO) NEW 7/8 0 X 4 1/2 LG. #7 HD. BUCKET TOOTH BOLTS INTO FRONT HOLES IN LIP, AND INSTALL 1 (ONE) 7/8 0 X 3 1/2 LG. #7 HD. BUCKET TOOTH BOLT IN IN REAR HOLE OF CLAMSHELL LIP. LINE UP TAB ON BOLT. WITH SLOT IN LIP.
2. INSTALL NEW TOOTH OVER 3 BOLTS INSTALL 7/8" LOCK-WASHER, AND 7/8 0 GRADE 8 HEX NUT ON BOLTS.
3. TORQUE NUTS TO APPROX. 600 FT. LBS. USING A 1 5/16" WRENCH OR SOCKET.

SEE ILLUSTRATION ON PAGE 29

GENERAL DISASSEMBLY

HEAD AND ARMS

1. LAY OPEN CLAMSHELL ON ITS SIDE WITH THE CLOSING LINE SOCKET ON THE HEAD FACING UPWARD.
2. ALLOW SLACK IN THE CLOSING LINE ROPE.

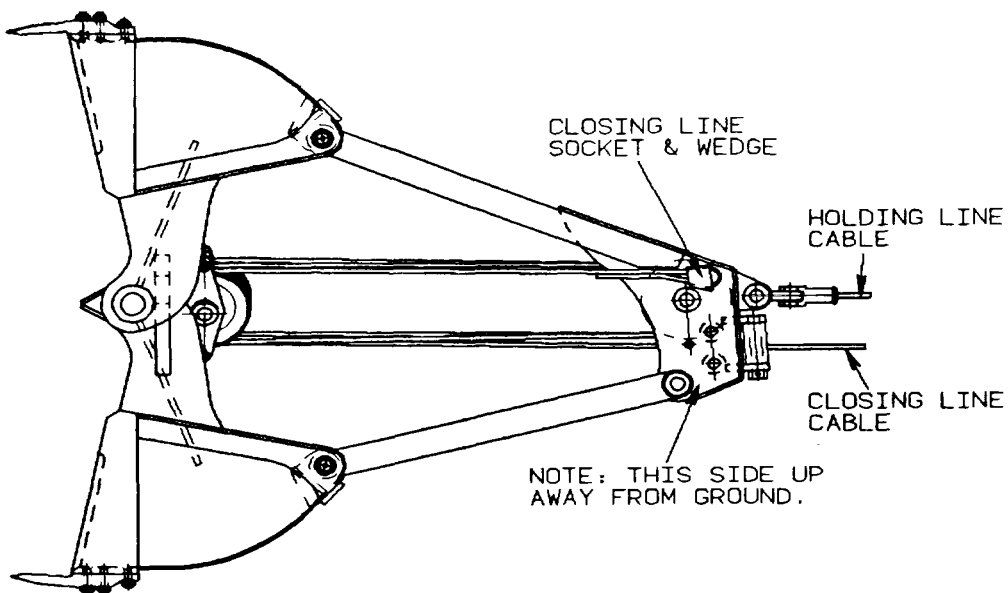

3. DRIVE CLOSING LINE ROPE WEDGE OUT OF THE SOCKET TOWARD THE TOP OF THE HEAD USING BACKING OUT PUNCH AND HAMMER.
4. SEPARATE WEDGE FROM ROPE.

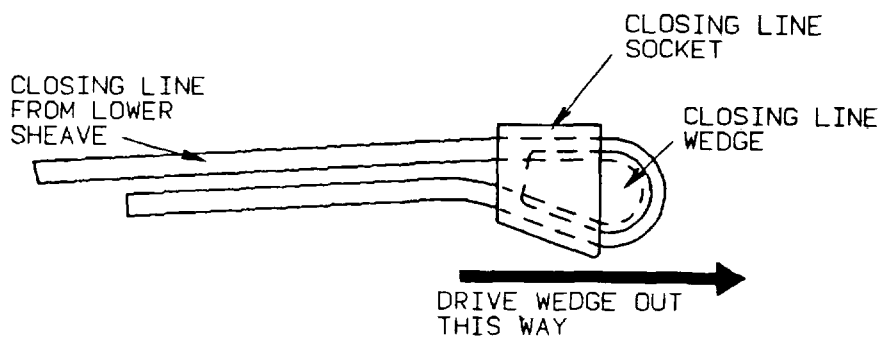

GENERAL DISASSEMBLY

HEAD AND ARMS

5. STAND OPEN BUCKET ON TEETH USING THE HOLDING LINE.
6. PULL CLOSING LINE COMPLETELY THROUGH THE UPPER ROLLERS.
7. REMOVE COTTER PINS FROM THE CORNER BRACKETS USING DRIFT AND HAMMER.
8. APPLY TENSION TO HOLDING LINE TO REMOVE WEIGHT OF HEAD AND ARM ASSEMBLY - FROM BRACKET PINS.
9. DRIVE BRACKET PINS THROUGH BRACKETS USING BACKING OUT PUNCH AND HAMMER.
10. LIFT HEAD AND ARM ASSEMBLY FROM BOWL USING HOLDING LINE FROM MACHINE.

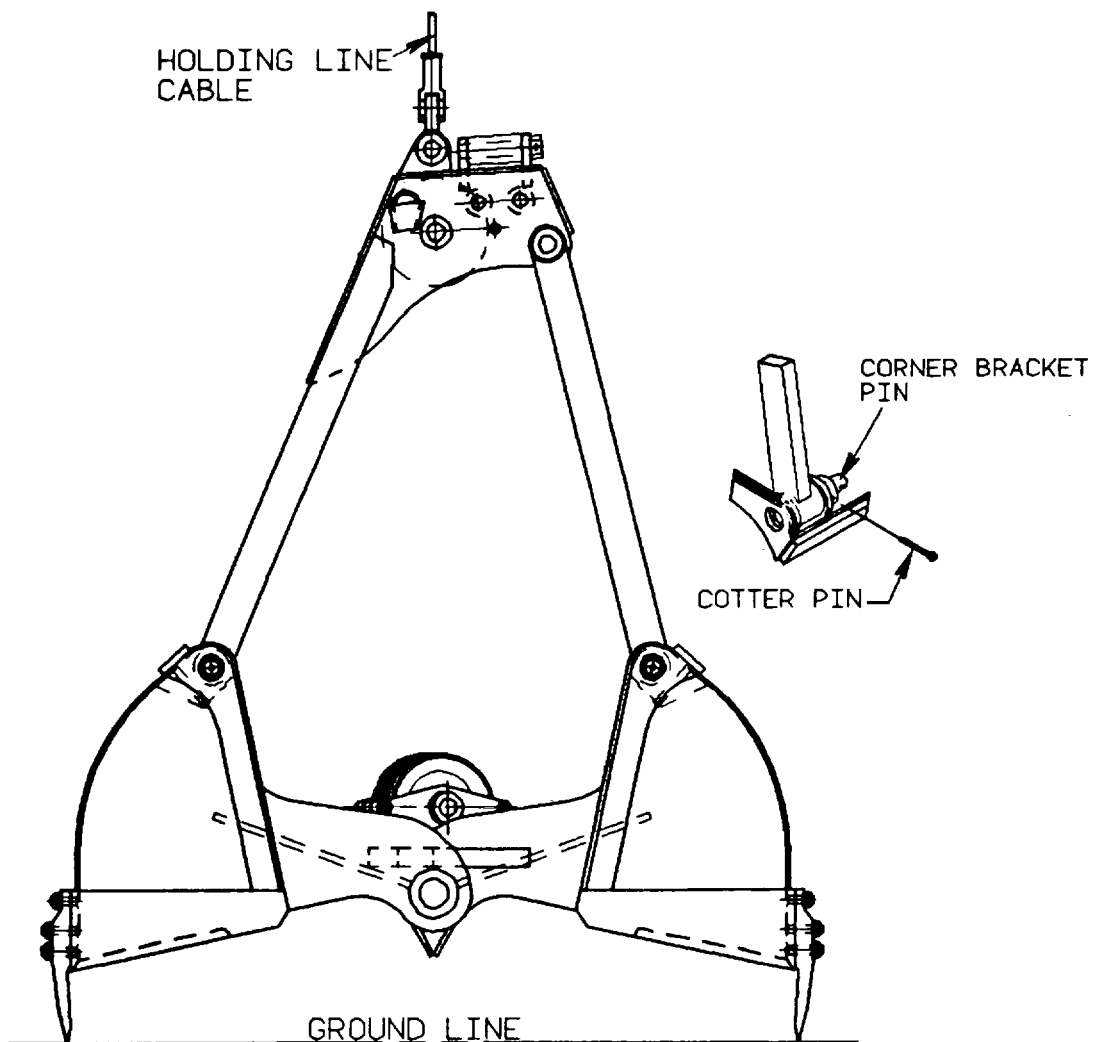

GENERAL DISASSEMBLY

HEAD AND ARMS

11. LAY HEAD AND ARM ASSEMBLY ON BACK OF FIXED ARMS SO THAT THE PIVOT ARMS ARE ON TOP.
12. ALLOW SLACK IN THE HOLDING LINE.
13. REMOVE COTTER PINS FROM THE PIVOT ARM AT THE UPPER PIN ARM BOSS USING DRIFT AND HAMMER.
14. SUPPORT PIVOT ARM WITH HOIST AND SLING AND DRIVE UPPER ARM PIN THROUGH ARM USING BACKING OUT PUNCH AND HAMMER. REPEAT FOR OTHER ARM.
15. LAY PIVOT ARMS ON HARD, CLEAN SURFACE.

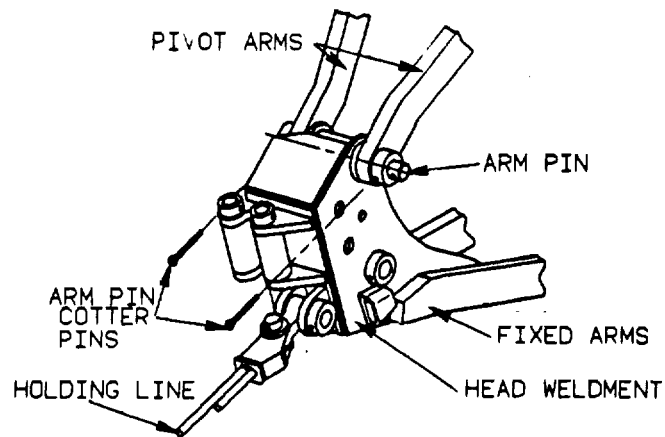
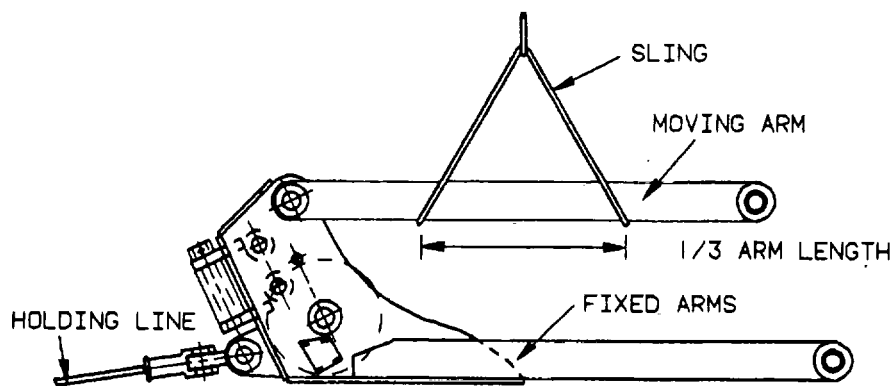

GENERAL DISASSEMBLY

HEAD AND ARMS

16. TURN HEAD ASSEMBLY TO REST ON FIXED ARMS AND PIVOT ARM HEAD TUBE.
17. ALLOW SLACK IN HOLDING LINE ROPE.
18. DRIVE HOLDING LINE WEDGE THROUGH SOCKET TOWARD THE SOCKET PIN USING BACKING OUT PUNCH AND HAMMER.
19. SEPARATE WEDGE FROM CABLE.

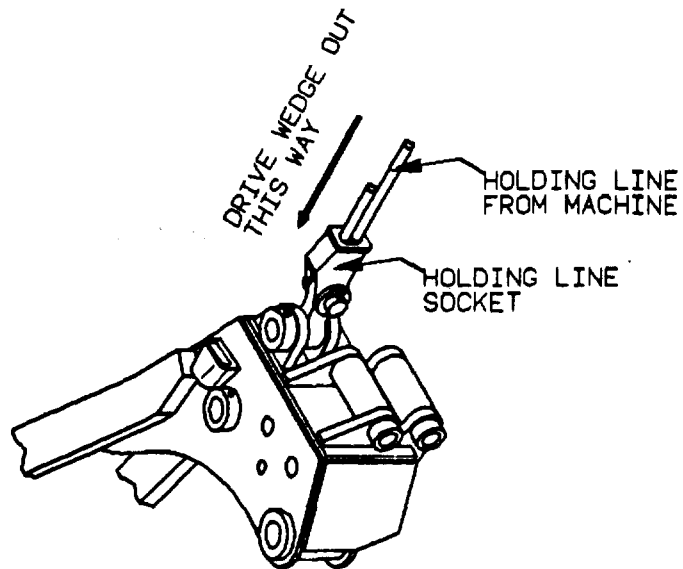
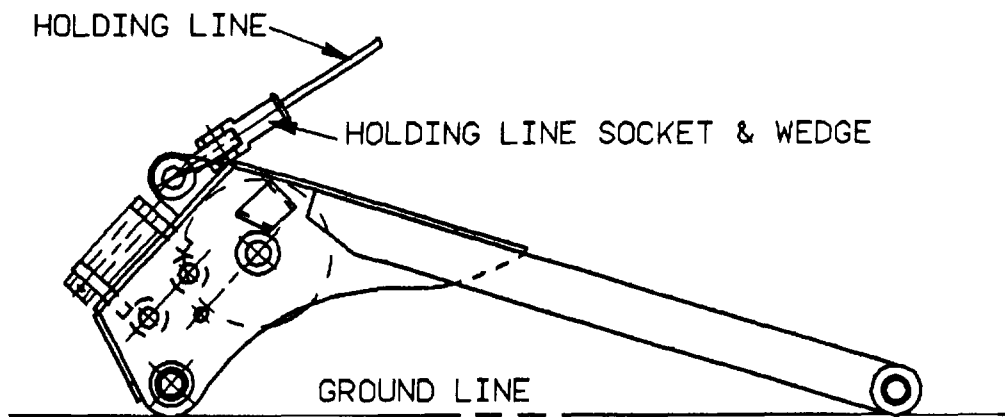

GENERAL DISASSEMBLY

HEAD AND ARMS

20. REMOVE COTTER PINS FROM THE HOLDING SOCKET PIN USING DRIFT AND HAMMER.
21. DRIVE HOLDING SOCKET PIN THROUGH THE SOCKET AND LINK USING BACKING OUT PUNCH AND HAMMER.
22. SEPARATE THE HOLDING SOCKET FROM LINK.
23. REMOVE COTTER PIN FROM THE HOLDING LINE PIN USING DRIFT AND HAMMER.
24. DRIVE HOLDING LINE PIN THROUGH HEAD LUGS USING BACKING OUT PUNCH AND HAMMER.
25. REMOVE LINK FROM HEAD LUGS

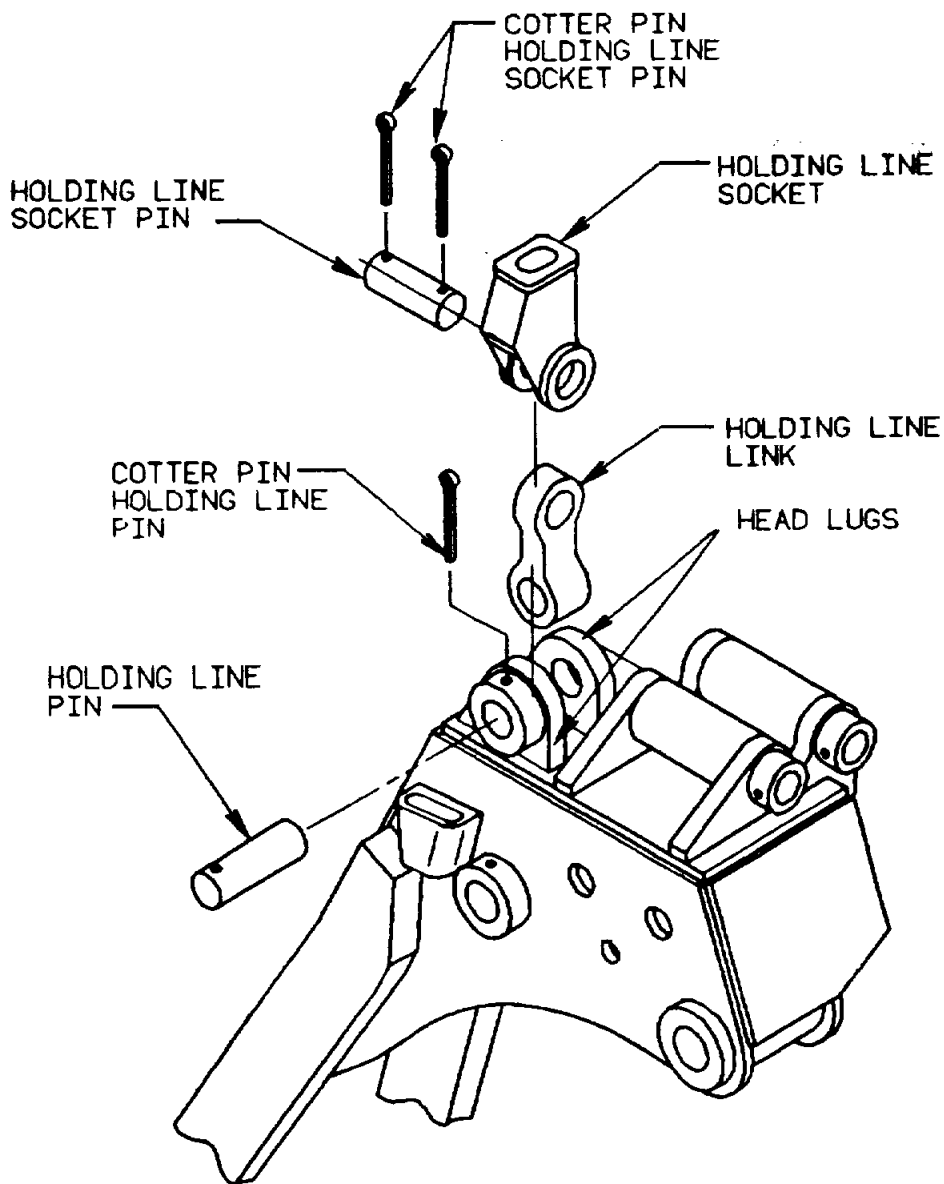

GENERAL DISASSEMBLY

HEAD AND ARMS

26. USING HOOK OR SLING THROUGH HOLDING LINE HEAD LUGS AND WITH HOIST, TURN ASSEMBLY TO REST ON BACK OF FIXED ARM WITH THE PIVOT ARM HEAD TUBE UP.
27. REMOVE HOOK OR SLING AND SUPPORT HEAD ASSEMBLY WITH WOOD BLOCK WEDGES, ONE EACH SIDE.
28. REMOVE COTTER PINS FROM THE UPPER ROLLER PINS USING DRIFT AND HAMMER.
29. DRIVE UPPER ROLLER PINS THROUGH HEAD LUGS USING BACKING OUT PUNCH AND HAMMER.
30. REMOVE UPPER ROLLERS FROM HEAD LUGS.
31. REMOVE COTTER PINS FROM LOWER ROLLER PINS USING DRIFT AND HAMMER.
32. DRIVE LOWER ROLLER PINS THROUGH HEAD PLATES USING BACKING OUT PUNCH AND HAMMER.
33. REMOVE LOWER ROLLERS FROM HEAD ASSEMBLY

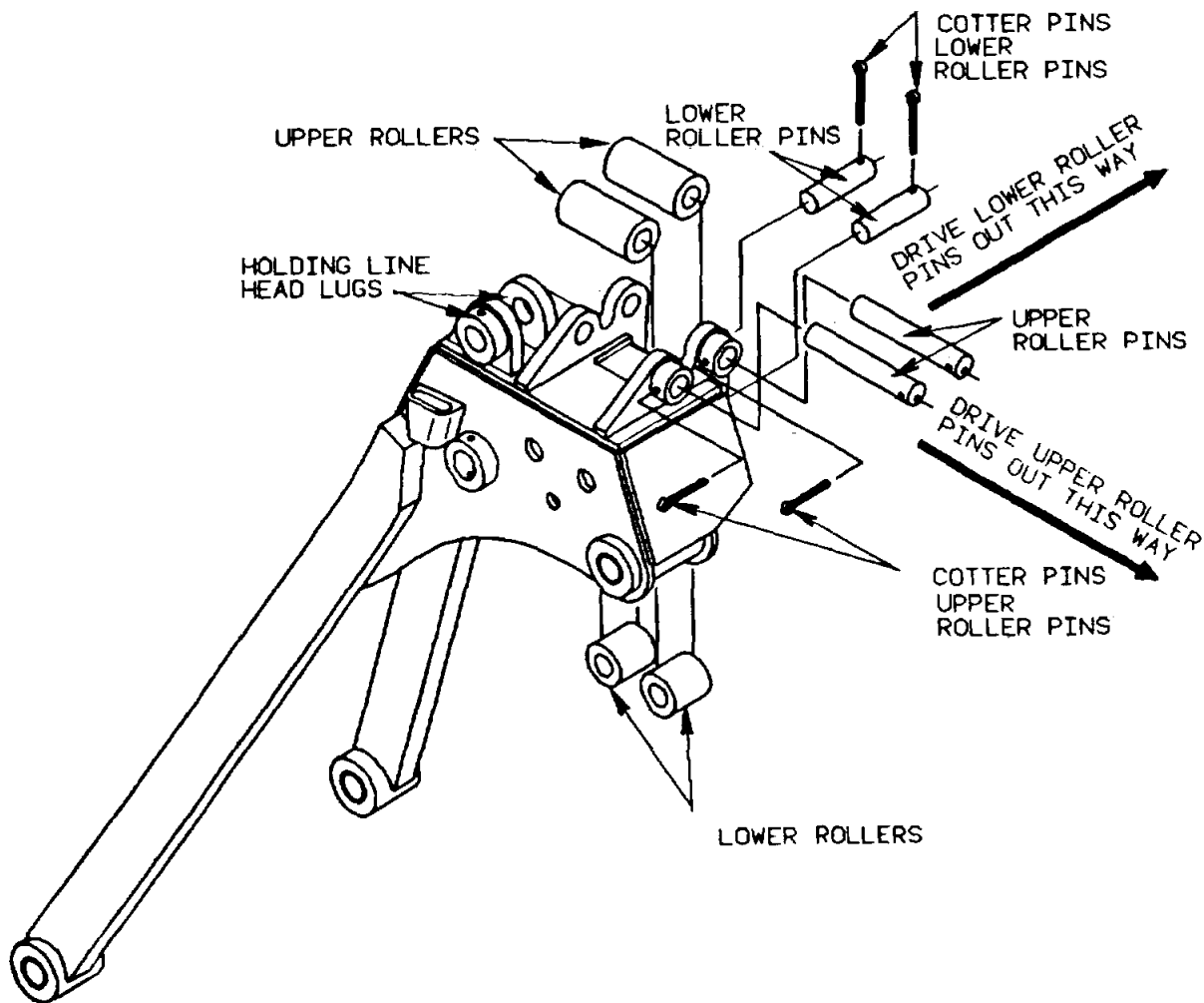

GENERAL DISASSEMBLY

HEAD AND ARMS

34. HOLD HEAD OF ROPE GUIDE BOLT USING 1 1/2 INCH WRENCH.
35. REMOVE ROPE GUIDE BOLT NUT USING 1 1/2 INCH SOCKET AND RATCHET.
36. DRIVE ROPE GUIDE BOLT THROUGH HEAD PLATES USING BACKING OUT PUNCH AND HAMMER.
37. REMOVE COTTER PIN FROM CLOSING SHEAVE PIN USING DRIFT AND HAMMER.
38. DRIVE CLOSING SHEAVE PIN THROUGH HEAD PLATES USING BACKING OUT PUNCH AND HAMMER.
39. REMOVE CLOSING SHEAVES AND SPACER FROM HEAD

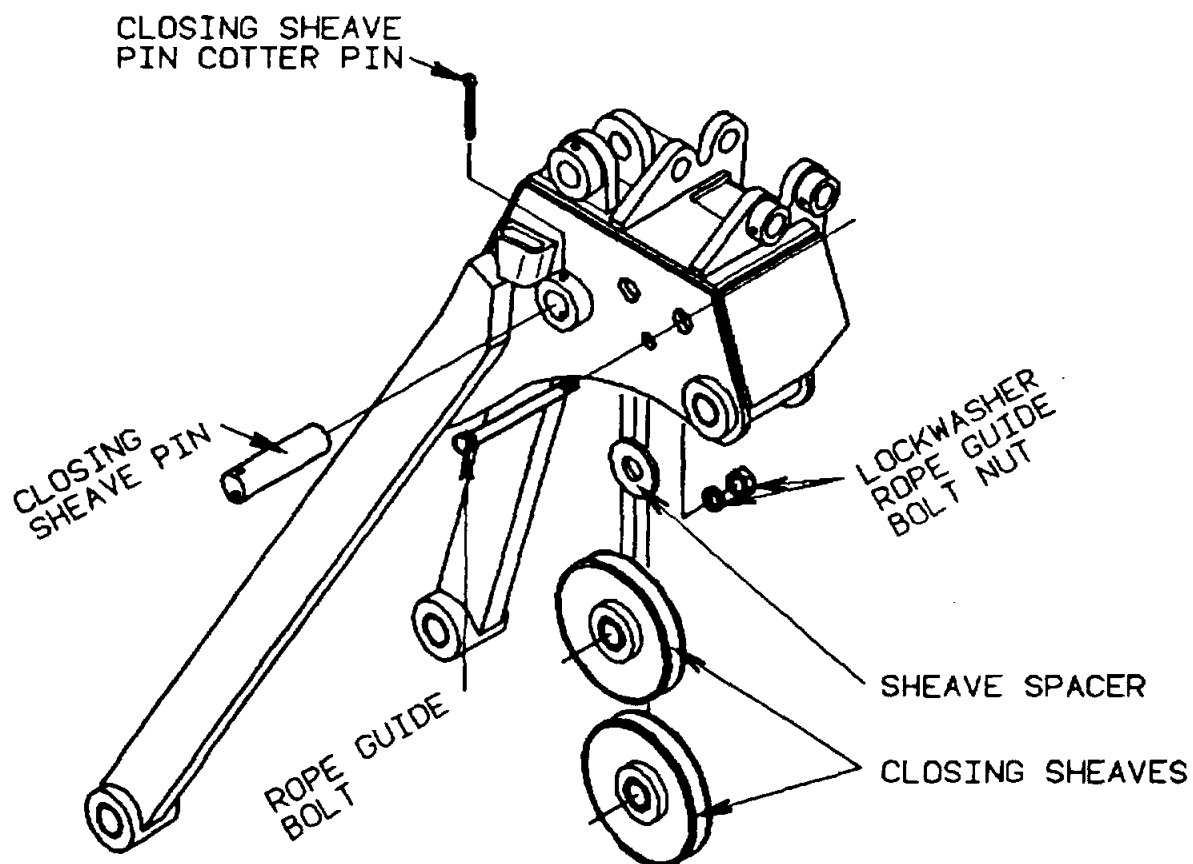

GENERAL DISASSEMBLY**HEAD AND ARMS**

40. CLEAN GREASE FROM ALL LOWER ARM BOSSES AND BUSHINGS.
41. APPLY BEAD OF WELD AROUND THE INSIDE OF THE BUSHINGS, APPROXIMATELY IN THE CENTER AND ALLOW TO COOL.
42. KNOCK OUT BUSHINGS USING HAMMER AND BACKING OUT PUNCH OR 2" DIAMETER BUSHING DRIVER.
43. LUBRICATE BUSHING BORES WITH LIGHT MACHINE OIL.
44. PLACE OUTSIDE FACE OF LOWER ARM BOSS ON A FIRM FLAT SURFACE AND SUPPORT OTHER END OF ARM WITH SLING AND HOIST.
45. CENTER BUSHING ON ARM BOSS BUSHING BORE AND SEAT BUSHINGS BY TAPPING AROUND EDGE OF BUSHING WITH A HAMMER.
46. DRIVE BUSHING COMPLETELY INTO ARM BOSS USING A HAMMER AND FLAT PLATE OR BEARING DRIVER.

NOTE: DO NOT HAMMER DIRECTLY ON BUSHING.

47. DUPLICATE STEPS 43 THROUGH 47 FOR EACH ARM.

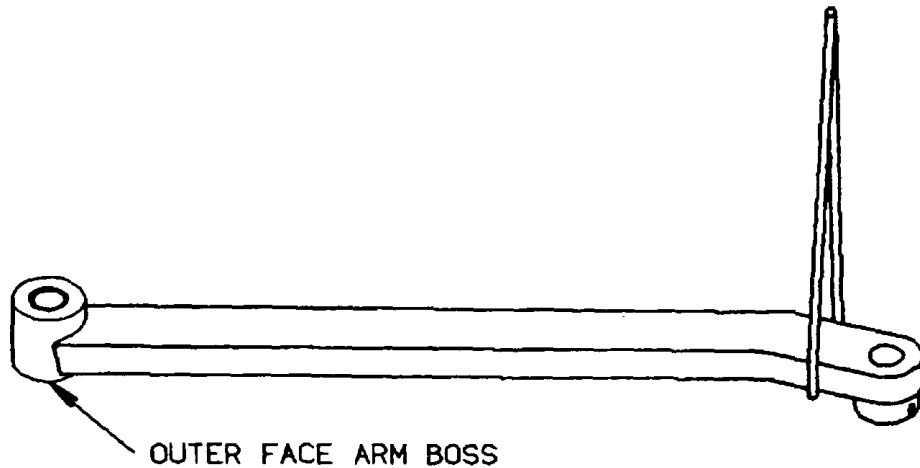

LOWER BLOCK, BOWLS & HINGES

1. REMOVE 1/2-13 UNC CAPSCREWS AND LOCKWASHERS FROM GROOVE CLEANER MOUNTING PLATE USING 3/4 SOCKET.
2. REMOVE GROOVE CLEANER MOUNTING PLATE COMPLETE WITH GROOVE CLEANER BOLTS AND JAM NUTS.
3. LAY GROOVE CLEANER ASSEMBLY ON CLEAN SURFACE.
4. REMOVE COTTER PIN FROM THE CLOSING SHEAVE PIN USING DRIFT AND HAMMER.
5. DRIVE SHEAVE PIN THROUGH THE LOWER BLOCK SHEAVE PLATES USING BACKING OUT PUNCH AND HAMMER.
6. REMOVE CLOSING SHEAVES.

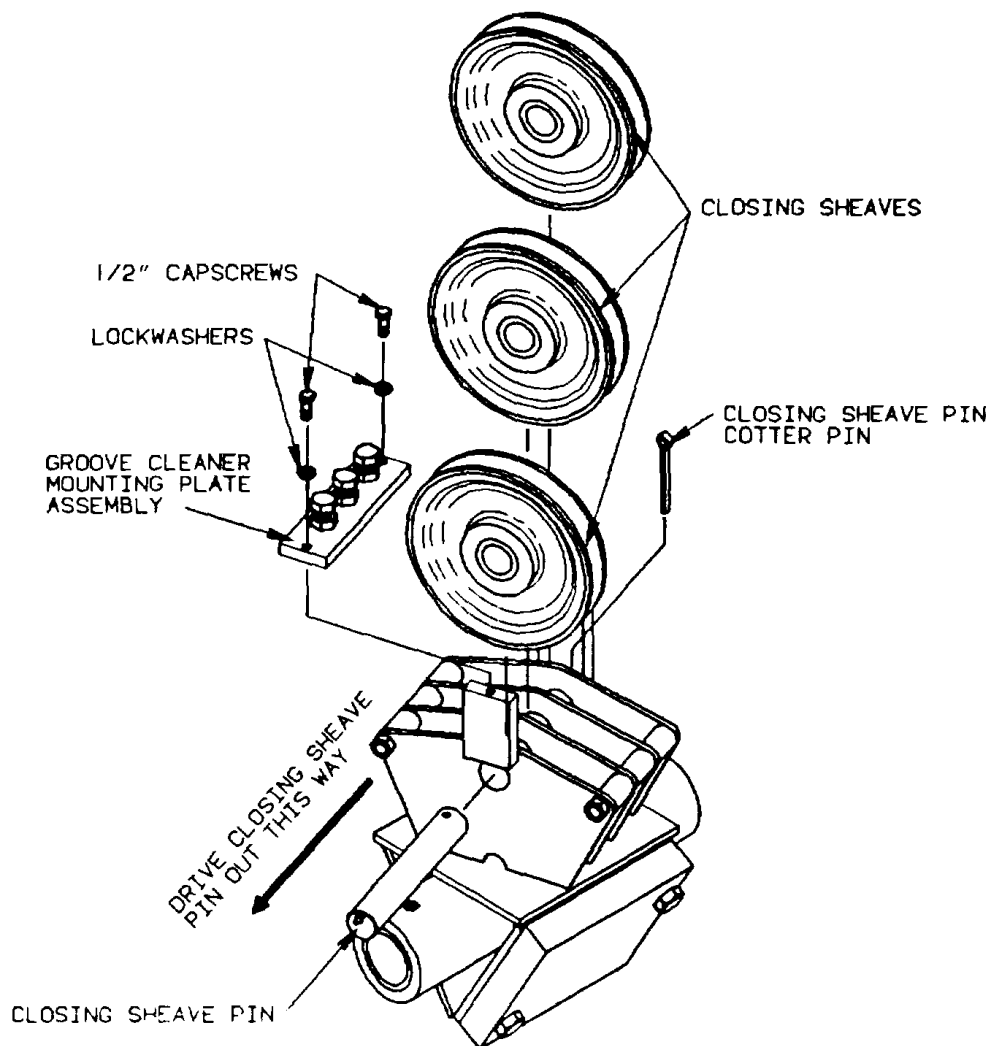

LOWER BLOCK, BOWLS & HINGES

7. HOOK OR SLING THROUGH THE LOWER BLOCK SHEAVE PIN HOLES AND POSITION OPEN BUCKET ON ITS SIDE USING HOIST.
8. REMOVE TEETH AS DESCRIBED IN TOOTH MAINTENANCE.(PAGE 28)
9. UPRIGHT BUCKET IN OPEN POSITION AND SUPPORT EACH BOWL ASSEMBLY ON WOOD BLOCKS AND WEDGES.

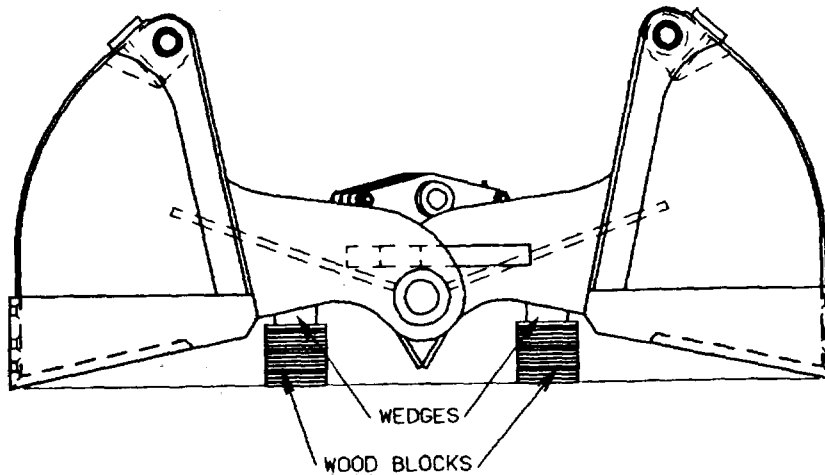

10. BURN OFF MAIN SHAFT RETAINING BOLT HEADS LOCATED ON OUTSIDE HINGE BOSS USING OXY-ACETYLENE TORCH.
11. DRIVE REMAINING BOLTS THROUGH HINGE BOSSES USING BACKING OUT PUNCH AND HAMMER.
12. LIFT ON HOOK OR SLING TO REMOVE LOWER BLOCK WEIGHT FROM MAIN SHAFT.
13. DRIVE MAIN SHAFT THROUGH HINGES AND LOWER BLOCK.

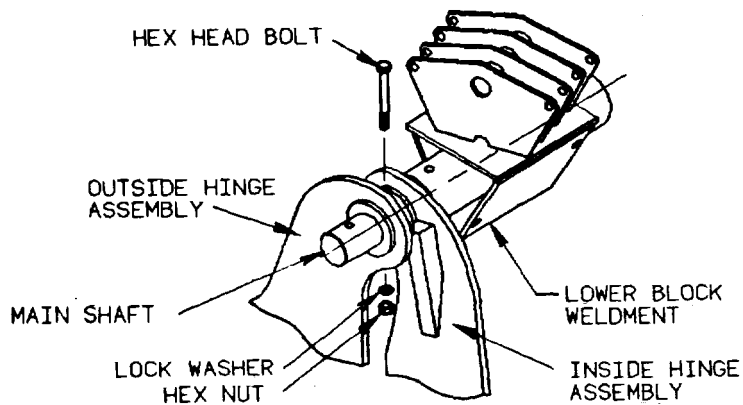

LOWER BLOCK, BOWLS & HINGES

14. LIFT LOWER BLOCK FROM BOWL ASSEMBLIES AND REST ON A CLEAN, HARD SURFACE ON ONE COUNTERWEIGHT PLATE.
15. WELD A LIFTING EYE TO THE CENTER OF THE EXPOSED COUNTERWEIGHT PLATE.
16. ATTACH A HOOK OR SLING TO THE LIFTING EYE AND SUPPORT USING A HOIST.
17. BURN OFF COUNTERWEIGHT PLATE BOLTS USING AN OXY-ACETYLENE TORCH AND REMOVE COUNTER WEIGHT USING A HOIST.
18. POSITION LOWER BLOCK ON OTHER SIDE TO EXPOSE REMAINING COUNTERWEIGHT PLATE.
19. DUPLICATE STEPS 15 THROUGH 18 FOR COUNTERWEIGHT PLATE REMOVAL.

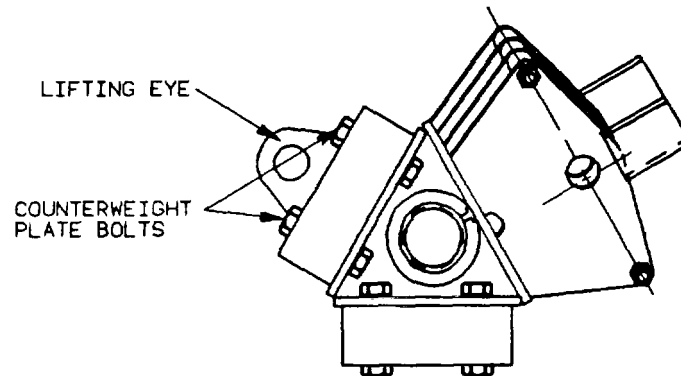

20. BURN OFF SPOOL BOLT NUTS WITH OXY-ACETYLENE TORCH.
21. DRIVE REMAINING SPOOL BOLTS THROUGH LOWER BLOCK SHEAVE PLATES USING BACKING OUT PUNCH AND HAMMER.

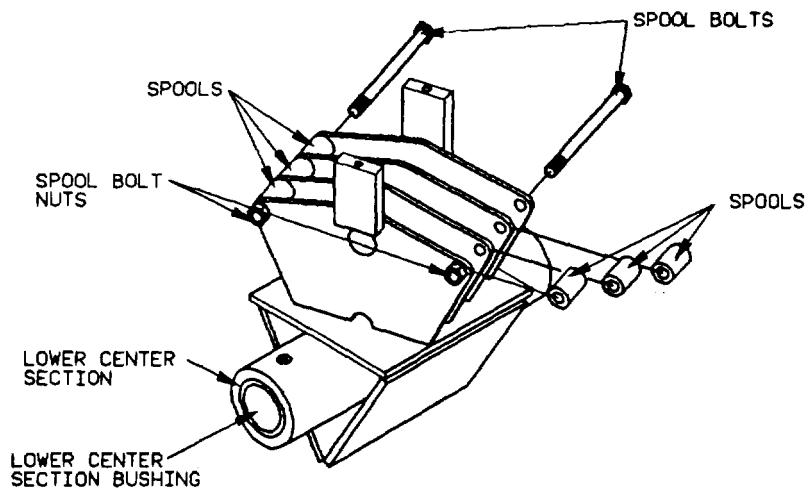

LOWER BLOCK, BOWLS & HINGES

23. CLEAN GREASE FROM BUSHING AT EACH END OF LOWER CENTER SECTION.
24. APPLY WELD AROUND INSIDE OF BUSHINGS APPROXIMATELY AT THE CENTER AND ALLOW TO COOL.
25. KNOCK BUSHING OUT OF TUBE FROM OPPOSITE END USING A

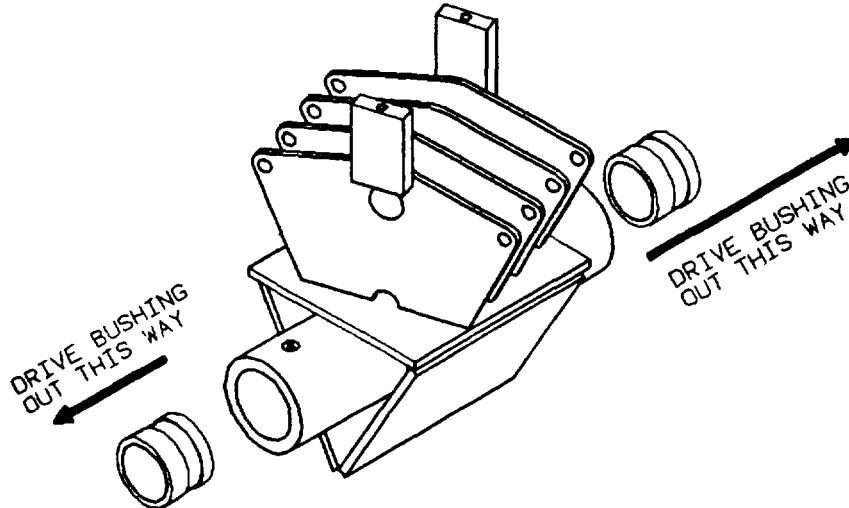

26. STAND LOWER BLOCK ASSEMBLY IN A VERTICAL POSITION ON ONE END OF THE TUBE, AND SUPPORT WITH SLING AND HOIST.
27. LUBRICATE BEARING BORE WITH LIGHT MACHINE OIL.
28. CENTER BUSHING AND START BY TAPPING AROUND EDGE WITH A HAMMER.
29. DRIVE BUSHING FLUSH USING A HAMMER AND METAL PLATE OR 3 3/4" DIAMETER BUSHING DRIVER.

NOTE

DO NOT HAMMER DIRECTLY ONTO BUSHING.

30. STAND LOWER BLOCK ON OTHER END AND SUPPORT.
31. DUPLICATE STEPS 24 THROUGH 26 FOR INSTALLATION OF OTHER BUSHING.

LOWER BLOCK, BOWLS & HINGES

32. SEPARATE THE BOWL ASSEMBLIES.
33. CLEAN THE GREASE FROM THE INSIDE HINGE BUSHINGS.
34. APPLY WELD AROUND INSIDE OF BUSHINGS APPROXIMATELY AT THE CENTER AND ALLOW TO COOL.
35. KNOCK BUSHING OUT OF HINGE USING HAMMER AND BACKING OUT PUNCH OR 3 3/4" DIAMETER BUSHING DRIVER.
36. TURN INSIDE HINGE BOWL ON ITS SIDE.
37. LUBRICATE HINGE BUSHING BORE WITH LIGHT MACHINE OIL.
38. CENTER BUSHING AND START BY TAPPING AROUND EDGE WITH A HAMMER.
39. DRIVE BUSHING FLUSH WITH A HAMMER AND METAL PLATE OR 3 3/4" DIAMETER BUSHING DRIVER.

NOTE: DO NOT HAMMER DIRECTLY ONTO BUSHING.

40. LAY BOWL ASSEMBLY ON THE OTHER SIDE AND DUPLICATE STEPS 37 THROUGH 39 FOR INSTALLATION OF OTHER BUSHING.

DISASSEMBLY OF BUCKET IS COMPLETE AND BUSHINGS HAVE BEEN RE-LACED. ASSEMBLY IS PERFORMED IN THE REVERSE ORDER.

SHEAVE BUSHING

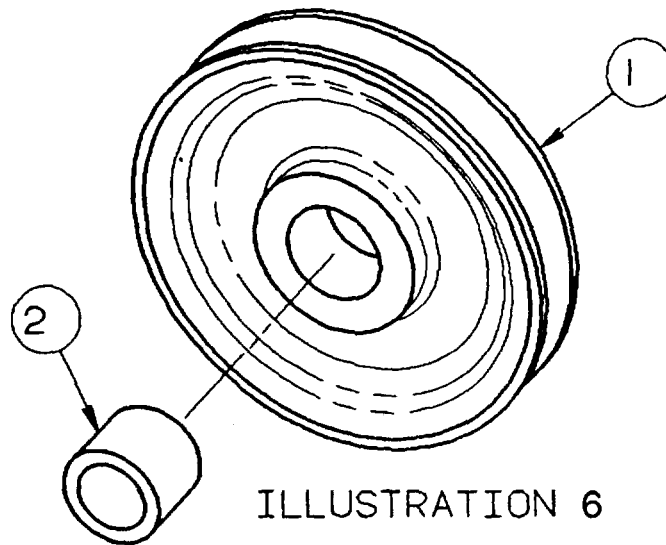

ILLUSTRATION 6

SHEAVE BUSHING DISASSEMBLY / ASSEMBLY

DISASSEMBLY:

1. SUPPORT RIM OF SHEAVE (ITEM 1) ON BLOCKS OF EQUAL HEIGHT.
2. DRIVE SHEAVE BUSHING (ITEM 2) THROUGH SHEAVE WITH HAMMER AND BACKING OUT PUNCH BY WORKING AROUND OUTER EDGE OF BUSHING.

ASSEMBLY:

1. LUBRICATE BUSHING BORE WITH LIGHT OIL.
2. LAY SHEAVE ON CLEAN, FLAT HARD SURFACE.
3. CENTER SHEAVE BUSHING (ITEM 2) IN BUSHING BORE AND TAP GENTLY AROUND OUTER EDGE TO SEAT.
4. CENTER A METAL PLATE OVER SHEAVE BUSHING AND DRIVE WITH HAMMER UNTIL BUSHING IS FLUSH.

NOTE: AN ARBOR PRESS MAY BE USED TO PERFORM DISASSEMBLY STEP 2 AND ASSEMBLY STEP 4. A 2 11/16 0 BUSHING DRIVER IS REQUIRED FOR PRESS.

TOOL LIST

ONE EACH OF THE FOLLOWING:

1. HAMMER, BLACKSMITH, 32 OZ. HEAD MINIMUM.
2. PIN PUNCH, 1/4 INCH, 3-1/2 INCH PIN LENGTH.
3. BACKING OUT PUNCH, 3/4 INCH PUNCH DIAMETER.
4. ADJUSTABLE WRENCH, CRESCENT TYPE, 18 INCH.(OPTIONAL)
5. REVERSIBLE RATCHET, 3/4 INCH SQUARE DRIVE.
6. 7/16 INCH SOCKET, 6 POINT, 1/2 INCH SQUARE DRIVE.
7. 3/4 INCH SOCKET, 12 POINT, 1/2 INCH SQUARE DRIVE.
8. 1-1/8 INCH SOCKET, 12 POINT, 3/4 INCH SQUARE DRIVE.
9. 1-5/16 INCH SOCKET, 12 POINT, 3/4 INCH SQUARE DRIVE.
10. 1-1/2 INCH SOCKET, 12 POINT, 3/4 INCH SQUARE DRIVE.
11. 3/4 INCH COMBINATION WRENCH.
12. 1-1/8 INCH COMBINATION WRENCH.
13. 1-5/16 INCH COMBINATION WRENCH.
14. 1-1/2 INCH COMBINATION WRENCH.
15. BUSHING DRIVER, 2-15/16 INCH DIAMETER, 3.00 INCH LONG.
16. BUSHING DRIVER, 3-3/4 INCH DIAMETER, 3-1/2 INCH LONG.
17. PRYING AND ALIGNING BAR.

TROUBLESHOOTING GUIDE

MALFUNCTION	PROBABLE CAUSE	CORRECTIVE ACTION
1 BUCKET WON'T OPEN (NEW BUCKET)	BOWL RESTRAINTS NOT REMOVED	REMOVE BOWL RESTRAINTS
2 BUCKET WON'T CLOSE	BROKEN CABLE CABLE WEDGED BETWEEN SHEAVE AND SHEAVE PLATES	REPLACE CABLE REMOVE CABLE FROM BETWEEN SHEAVE AND SHEAVE PLATE REREVEE BUCKET
3 ROLLER WON'T TURN	DEBRIS BETWEEN ROLLER AND PIN NO GREASE IN ASSEMBLY	REMOVE ROLLER, PIN CLEAN AND REGREASE REMOVE ROLLER, PIN CLEAN AND REGREASE
4 SHEAVE WON'T TURN	DEBRIS BETWEEN SHEAVE AND PIN NO GREASE IN ASSEMBLY	REMOVE SHEAVE, PIN CLEAN AND REGREASE REMOVE SHEAVE, PIN CLEAN AND REGREASE

WARRANTY

1. INTERGY WARRANTS THE CLAMSHELL AND DRAGLINE BUCKETS TO BE FREE FROM DEFECTS IN MATERIAL AND WORKMANSHIP FOR A PERIOD OF EIGHT (8) MONTHS FROM THE DATE OF GOVERNMENT ACCEPTANCE OF EACH BUCKET (AS EVIDENCED IN THE ACCEPTANCE BLOCK OF THE DD FORM 250).
2. IN THE EVENT THAT A DEFECT OR FAILURE IN MATERIAL OR WORKMANSHIP OCCURS WITHIN THE WARRANTY PERIOD, INTERGY WILL PROVIDE, AT ONE OF ITS FACILITIES OR AT ANOTHER FACILITY APPROVED IN ADVANCE IN WRITING BY INTERGY, THE FOLLOWING:
 - A.) COMPLETE REPAIR OF THE DEFECTIVE PRODUCT, OR IF INTERGY DEEMS REPAIR TO BE IMPRACTICAL OR NOT FEASIBLE, A NEW ATTACHMENT OR PART.
 - B.) REASONABLE AND CUSTOMARY LABOR CHARGES (DURING NORMAL WORKING HOURS) NEEDED TO EFFECT REPAIR OR REPLACEMENT OF THE DEFECTIVE ITEM.
 - C.) SHIPPING CHARGES FOR SHIPMENT, BY MEANS AND METHODS SELECTED BY INTERGY, TO THE USER'S LOCATION FOR REPLACEMENT PARTS AND PRODUCTS.
3. THE GOVERNMENT SHALL BE RESPONSIBLE FOR ALL THINGS NOT LISTED IN THIS ITEM 3 INCLUDING, BUT NOT LIMITED TO, THE FOLLOWING:
 - A.) FREIGHT COSTS AND ANY OTHER EXPENSES FOR RETURN TO INTERGY OF ANY DEFECTIVE BUCKET OR PART REQUIRING REPAIR OR REPLACEMENT.
 - B.) ANY LOSS OF OR DAMAGE TO ANY BUCKET OR PART IN TRANSIT WHILE BEING SHIPPED TO AND FROM INTERGY, INCLUDING THE FILING AND PROCESSING OF ANY CLAIM AGAINST ANY CARRIER.
 - C.) FREIGHT COSTS AND ANY OTHER EXPENSES FOR SHIPMENT FROM INTERGY'S FACILITIES TO THE USER'S LOCATION IN THE EVENT ANY ATTACHMENT OR PART IS RETURNED TO INTERGY WITHOUT ITS PRIOR WRITTEN AUTHORIZATION.
 - D.) TO PROMPTLY NOTIFY INTERGY UPON DISCOVERY OF ANY CLAIMED DEFECT OR FAILURE, BY MEANS OF DD FORM 2407.
 - E.) TO FURNISH EVIDENCE ACCEPTABLE TO INTERGY THAT AN ITEM ALLEGED TO BE DEFECTIVE IS WITHIN THE APPLICABLE WARRANTY PERIOD.

WARRANTY

- F.) THE EXPENSE OF ANY SERVICE CALL FOUND TO BE UNNECESSARY BY INTERGY.
- G.) ANY CHARGES FOR TIME AND LABOR BEYOND RATES SPECIFIED AND APPROVED BY INTERGY AND ANY CHARGES IN EXCESS OF THOSE APPLICABLE TO THE FOLLOWING STANDARD REPAIR TIME:
 - 1.) CUT OUT OLD AND INSTALL NEW CUTTING EDGE -- 4.0 HOURS.
 - 2.) REMOVE AND REPLACE ANY BOLT-ON EDGE -- 1.5 HOURS.

NO CHARGES OUTSIDE OR BEYOND THE LIMITATIONS STATED IN THIS ITEM 3 WILL BE ACCEPTED UNLESS WRITTEN AUTHORIZATION HAS BEEN ISSUED BY INTERGY PRIOR TO THE PERFORMANCE OF ANY WORK.

4. INTERGY SHALL NOT BE RESPONSIBLE FOR:

- A.) ANY FAILURE CAUSED BY OR RESULTING FROM THE IMPROPER USE OR NORMAL WEAR AND TEAR ON AN ATTACHMENT. IF UNSURE AS TO COVERED USES, CONTACT INTERGY AT 1-800-321-8175.
- B.) ANY FAILURE RESULTING FROM IMPROPER INSTALLATION PROCEDURES.
- C.) ANY FAILURE CAUSED BY UNAUTHORIZED MODIFICATIONS TO THE BUCKETS. NO MODIFICATIONS MAY BE MADE WITHOUT PRIOR WRITTEN AUTHORIZATION BY INTERGY.
- D.) ANY OVERTIME CHARGES OR COSTS FOR REPAIR OF ANY DEFECTIVE OR FAILED ITEM.

5. THE GOVERNMENT WILL NOTIFY INTERGY OF ANY WARRANTY DEFECTS VIA A DD FORM 2407. THE MAILING ADDRESS FOR ANY WARRANTY CLAIM:

INTERGY, INC.
ANVIL ATTACHMENTS
10100 BRECKSVILLE RD.
P.O. BOX 418051
BRECKSVILLE, OH 44141-3206

6. WARRANTY REIMBURSEMENT CHECKS SHALL BE SUBMITTED TO TACOM, ATTN: AMSTA-EFD, WARREN, MI, 48347-5000, IDENTIFIED BY CLAIM NUMBER, UNIT IDENTIFICATION CODE CUIC) OF EACH CLAIM, TOTAL DOLLARS INVOLVED AND CONTRACT NUMBER. CHECKS SHALL BE PAYABLE TO

"FINANCE AND ACCOUNTING OFFICER, USA TACOM."

WARRANTY

7. THIS WARRANTY IS IN LIEU OF AND EXCLUDES ALL OTHER WARRANTIES EXPRESSED OR IMPLIED, INCLUDING, WITHOUT LIMITATION, MERCHANTABILITY OR FITNESS FOR A PARTICULAR PURPOSE. INTERGY SHALL NOT BE LIABLE FOR ANY CONSEQUENTIAL LOSSES OR DAMAGES, DELAYS OR ANY OTHER COST OR EXPENSE ARISING FROM THE USE OF PRODUCTS AND THE REMEDY AND RECOVERY OF GOVERNMENT ON ANY CLAIM WHETHER BASED ON THE CONTRACT, THIS WARRANTY OR ANY ALLEGED NEGLIGENCE OF INTERGY SHALL BE AS STATED AND LIMITED HEREIN AND SHALL BE EXCLUSIVE.

SUPPLEMENTAL OPERATING, MAINTENANCE
AND
REPAIR PARTS INSTRUCTIONS
FOR
BUCKET, CLAMSHELL, 3/4 CU. YD.
MODEL 34GP S

TABLE OF CONTENTS

SECTION I	GENERAL	PARA.	PAGE
	Purpose	1	49
	Scope	2	49
	Military Adopted Commercial Items	3	49
	Description	4	49
	Operational Concepts	5	49
	Equipment Publications	6	49
	Personnel Required	7	49
	Logistics Assistance	8	49
	Warranty	9	49
	Recommending Publications Changes	10	49
	Operational Equipment Required	11	50
SECTION II	MAINTENANCE		
	Maintenance Concept	1	51
	Maintenance Allocation Chart (MAC)	2	51
	Modifications	3	51
	Equipment Improvement Recommendations (EIRs)	4	51
	Shipment and Storage	5	51
	Destruction to Prevent Enemy Use	6	51
	Basic Issue Items List (BIIL)	7	51
	Special Tools and Equipment	8	51
	Maintenance and Operating Supplies	9	51
	Maintenance Forms and Records	10	52
	Lubrication	11	52
	Quality Deficiency Reports (QDR)	12	52
	Maintenance Expenditure Limits (MEL)	13	52
	Fire Protection	14	52
	Mixture of Inch and Metric Fasteners	15	53
SECTION III	REPAIR PARTS SUPPLY		
	General	3-1	54
	Initial Prescribed Load List (PLL)	3-2	54
	Initial Authorized Stockage List (ASL)	3-2	54
APPENDIX			
A	1. Maintenance Allocation Chart Introduction		A-1
	2. Maintenance Allocation Chart		A-3
	3. Special Tools and Test Equipment Requirements		A-4

TABLE OF CONTENTS

APPENDIX		PAGE
B	1. Operator/Crew Preventive Maintenance Checks and Services (PMCS)	B-1
	2. Unit Preventive Maintenance Checks and Services (PMCS)	B-5
C.	1. Basic Issue Items	C-1
	2. Items Troop Installed, Additional Authorized Items	
D.	Maintenance of Operating Supply List	D-1
E.	Publications	E-1
F.	Lubrication Order	F-1
G.	DA Form 2765 (Sample)	G-1
H.	Direct Supply Support Project Code	H-1
I.	Milstrip Request Using NSNs	I-1
J.	Milstrip Request for Parts Without NSNs	J-1
K.	Milstrip Request for Manual Submission	K-1
L.	Format for Non-NSN Requests	L-1
M.	Format for NSN Requests	M-1
N.	Source Code Definitions	N-1

SECTION I**GENERAL**

1. **PURPOSE:** To Provide user and support personnel supplemental operating, maintenance and repair parts instructions that have special application to Military Adopted Commercial Items (MACI).
2. **SCOPE:** This application applies to Department of the Army units, organizations and activities that use and/or support the Bucket, Clamshell, INTERGY Model 34GP S.
3. **MILITARY ADOPTED COMMERCIAL ITEM (MACI):** The term "MACI Item" used in this publication applies to a standard commercial item of construction equipment that has been approved and adopted by the Army for a specific TOE requirement and is procured and supported under the CCI system plan. The plan permits maximum utilization of the civilian construction industry's competitive research and development, manufacturer's equipment publications and commercial sources for repair parts.
4. **DESCRIPTION:** The clamshell has a single main shaft block and tackle type of construction. The clamshell is designed to use its weight, pitch of teeth, sharpness and angle of the lip in connection with the machine line pull to draw the bucket downward into the material. Gravity causes the main shaft to move down pushing the bowls downward and outward to dump the load.
5. **OPERATIONAL CONCEPT:** The clamshell bucket is designed to be used with a crane having a lattice or solid boom for excavating or dredging. It is portable and is used by Engineer Construction Support Companies and Engineer Port Construction Companies.
6. **EQUIPMENT PUBLICATIONS:** Initial publications are a commercial manual and Supplemental Operating, Maintenance and Repair Parts Instructions (SOMARPI). Two manuals will be overpacked and shipped with each end item. Department of the Army publications will be forthcoming and will be available through the normal publications supply channels.
7. **PERSONNEL REQUIRED:**
 - a. **MOS Requirements:** In accordance with AR 611-201
 - (1) Crane Operator: MOS 62F
 - (2) Organizational Maintenance: MOS 62B
 - (3) Direct/General Support Maintenance: MOS 62B
 - b. Depot Maintenance is not required.
8. **LOGISTICS ASSISTANCE:** Logistics Assistance Representatives (LARs) are stationed at CONUS and OCONUS installations and are available to provide on-site technical assistance, upon request from the installation.
9. **WARRANTY:** Warranty period for the Bucket, Clamshell, Model 34GP S is eight (8) months following the date of acceptance by the government. See the manufacturers commercial manual for the warranty.
10. **RECOMMENDING PUBLICATION CHANGE:** You can improve this publication by recommending improvements, using DA Form 2028 (Recommended Changes to Publications and Blank Forms) and mail direct to: Commander, U.S. Army Tank-Automotive Command, ATTN: AMSTA-MB, Warren, MI 48397-5000.

11. OPERATIONAL EQUIPMENT REQUIREMENTS:

a. The clamshell may be used with any of the following cranes:

	NSN	MODEL TM 5-3815-225-13&P
(1)	3810-00-043-5354	2385 20 ton RT
(2)	3810-00-763-7728	2380 20 ton RT
(3)	3810-00-275-1167	M320 RT 20 ton
(4)	3810-00-542-3048	855BG2 40 ton
(5)	3810-00-542-3049	855BG2 40 ton
(6)	3810-00-606-3569	855BG 40 ton
(7)	3810-00-786-5200	855BG 40 ton
(8)	3810-00-933-0588	855BG 40 ton
(9)	3810-00-933-0589	855BG 40 ton
(10)	3810-00-933-0590	855BG3 40 ton
(11)	3810-01-145-8288	5060 40 ton
(12)	3810-00-151-4431	M320T-2 20 ton truck/crane
(13)	3810-00-527-8613	M-20AF 20 ton truck/crane
(14)	3810-00-542-4980	M200W 20 ton truck/crane
(15)	3810-00-542-4982	M200 20 ton truck/crane
(16)	3810-00-820-0698	M202 20 ton truck/crane
(17)	3810-00-861-8088	M320T 20 ton truck/crane
(18)	3810-00-989-0505	2360 20 ton truck/crane
(19)	3810-00-869-3092	22BM 12 1/2 ton
(20)	3810-00-937-3939	L36M 12 1/2 ton
(21)	3810-00-018-2021	MT250 25 ton hydraulic
(22)	3810-01-054-9779	TMS300-5 25 ton hydraulic

b. There is no separately authorized equipment required to transport this bucket.

SECTION II**MAINTENANCE**

1. MAINTENANCE CONCEPT: Operators shall possess a MOS of 62F and maintenance will be performed by a 62B MOS. This is a Non-Development Item (NDI), as such, there is no maintenance engineering effort on the part of the Army. The level of maintenance will be assigned in accordance with maintenance policies and procedures and the Maintenance Allocation Chart (MAC). The level of maintenance identified in the MAC should be reflective of training and repair parts support for similar equipment in the military inventory. Unit thru depot maintenance must be considered.

- a. **MAINTENANCE PLAN:** Maintenance capabilities will be governed by the MAC and will be tailored to accommodate the complexity of the maintenance requirement.
- b. **UNIT MAINTENANCE:** Unit Maintenance is performed by a crew, the operator, or unit maintenance personnel as shown in the MAC of the appropriate TM or commercial manual. Unit Maintenance normally includes inspection by sight and touch of easily accessible components; lubrication, cleaning, preserving, tightening and isolation using BITE, go no-go or on board instrumentation (if applicable); and the replacement of easily removed and installed components that do not require other than common tools.
- c. **INTERMEDIATE DIRECT SUPPORT MAINTENANCE:** Intermediate Direct Support Maintenance is performed by installation shops and selected intermediate maintenance support units and activities in the Army force structure. Intermediate Direct Support Maintenance will remove and replace major assemblies and components and provide contact maintenance teams for local support of unit maintenance when required. Intermediate Direct Support Maintenance personnel shall be capable of diagnosing causes of equipment failures, repairing specified components and repair parts so they may be returned to the supply system in support of the clamshell bucket. This maintenance level shall maintain a supply support system which allows unit maintenance to obtain repair parts through reparable exchange (RX) and requisitions.
- d. **DEPOT MAINTENANCE:** No depot maintenance programs are planned for the overhaul of these buckets.

2. MAINTENANCE ALLOCATION CHART (MAC): (See Appendix A) Units may exceed their authorized scope and function in the MAC when approved by the support maintenance commander.

3. MODIFICATION: Modifications will be accomplished by the end item manufacturer after TACOM approves the field campaign or modification plan.

4. EQUIPMENT IMPROVEMENT RECOMMENDATIONS (EIR): Equipment Improvement Recommendations will be submitted in accordance with DA PAM 738-750.

5. SHIPMENT AND STORAGE: Refer to the manufacturer's manual and TB 740-97-2. Packaging, handling and storage will be IAW MIL-H-21103D.

6. DESTRUCTION TO PREVENT ENEMY USE: Refer to TM 750-244-3, and FM 5-25 for instructions governing destruction of equipment to prevent enemy use.

7. BASIC ISSUE ITEMS LIST (BIIL): None

8. SPECIAL TOOLS AND EQUIPMENT: None

9. MAINTENANCE AND OPERATING SUPPLIES: See Appendix for a list of maintenance and operating supplies required for initial operation.

10. MAINTENANCE FORMS AND RECORDS:

- a. Operational Records: Operational records (DD Form 1970, daily dispatch and DA Form 2401, Equipment Control Record) will be used to control the use and record operators and locations of equipment operation.
- b. Maintenance Records:
 - (1) SF91 Accident Form
 - (2) DD 518 Accident Identification Card
 - (3) DD Form 314, Preventive Maintenance Schedule and Records
 - (4) DA Form 2404, Equipment Inspection and Maintenance Worksheet
 - (5) DA Form 2407, Maintenance Request
 - (6) DA Form 2408-14, Uncorrected Faults Record
- c. Historical Records:
 - (1) DA Form 2408, Equipment Log Book Assembly
 - (2) DA Form 2408-9, Equipment Control Record

11. LUBRICATION: To insure proper operation of this equipment, all points requiring lubrication must be serviced with the correct lubrication, at the proper time intervals. All lubrication points requiring service as shown on the lubrication chart (Appendix H).

- a. Points not equipped with lubrication fittings (clevis, pins, lever, linkages etc.) should be lubricated according to working and climate conditions with an oil squirt can using OE 30.
- b. Intervals specified are for normal operations where moderate temperatures, humidity, and atmospheric conditions prevail. In areas of extreme conditions the service periods should be adjusted accordingly.

12. QUALITY DEFICIENCY REPORT (QDR): STANDARD FORM 368 (Quality Deficiency Report) was adopted for Equipment Improvement Recommendation (EIR) reporting. This action was taken to standardize reporting within all governmental services. Submissions to be in accordance with DA Pam 738-750.

13. MAINTENANCE EXPENDITURE LIMITS: The average life expectancy for the Clamshell, Bucket is 18 years.

REPAIR LIMITS	YEAR
50%	1992
45%	1994
40%	1996
35%	1998
30%	2002
25%	2006

14. FIRE PROTECTION:

- a. A hand operated fire extinguisher may be positioned at the work site by the using unit, 15 feet from the equipment.
- b. Refer to TB 5-4200-200-10, Hand Portable Fire Extinguishers Approved for Army users.

15. MIXTURE OF INCH AND METRIC FASTENERS:

- a. The use of world-wide sources for components has made it possible for Foundation Equipment Corporation (FEC) products to have a mixture of inch and metric fasteners. For example, metric fasteners may be used on the fuel pump, guides, etc., and other components. It is possible that the internal bolts on a component may be metric while the mounting bolts may be inch size.
- b. To help mechanics know when metric fasteners are used on a product, future service publications such as parts books, Operation and Maintenance Manuals will use a notice similar to the one that follows.

WARNING

Avoid mixing metric and inch (customary) fasteners. Mismatched or incorrect fasteners can result in equipment damage or malfunction, or possible personal injury. Original fasteners removed from the vehicle should be saved for assembly when possible. If new ones are required, caution must be taken to replace with one that is of the same part number and grade or better.

SECTION III**REPAIR PARTS SUPPLY****3-1 General**

- a. The basic policies and procedures in AR 710-2 and AR 725-50 are generally applicable to repair parts management for this item. See Appendix J thru O for MILSTRIP samples, formats and source codes.
- b. National Stock Numbers (NSN) will be assigned to all repair parts expected to be replaced at any maintenance level.
- c. Prior to submitting requisitions for repair parts, the Commercial and Government Entity (CAGE) and the part number must be screened to identify possible NSNs.
- d. Repair parts not immediately available through the Department Of Defense Supply System may be locally purchased IAW AR 725-50, para. 3-29.

3-2 Prescribed Load/Authorized Stockage List (PLUASL):

- a. The PLL is a 15 day supply of parts recommended for Initial stockage at the organizational level of maintenance. Management of PLL items is governed by AR 710-2 and local command procedures. There is no Initial PLL authorized for this bucket.
- b. The ASL is an estimated 45 day supply of repair parts for support units and activities. There is no initial ASL authorized for this bucket.

APPENDIX A

MAINTENANCE ALLOCATION CHART

FOR

BUCKET, CLAMSHELL NSN 3815-01-249-4092

Intergy, Inc. Model 34GP S

Section I Introduction

1. **General:** This Maintenance Allocation Chart (MAC) designates responsibility for performance of maintenance functions to specific maintenance categories.

2. **Maintenance Functions:** Maintenance functions will be limited to and defined as follows:

- a. **Inspect:** To determine the serviceability of an item and detect incipient failure by comparing its physical, mechanical and/or electrical characteristics with established standards through examination.
- b. **Test:** To verify serviceability and detect incipient failure by measuring the mechanical or electrical characteristics of an item and comparing those characteristics with prescribed standards.
- c. **Service:** Operations required periodically to keep an item in proper operating condition, i.e., to clean (decontaminate), to preserve, to drain, to paint or to replenish fuel, lubricants, hydraulic fluids, or compressed air supplies.
- d. **Adjust:** To maintain, within prescribed limits, by bringing into proper or exact position, or by setting the operating characteristics to specified parameters.
- e. **Install:** The act of emplacing, seating or fixing into position an item, part, or module (component or assembly) in a manner to allow the proper functioning of an equipment or system.
- f. **Replace:** The act of substituting a serviceable like-type part, subassembly, or module (component or subassembly) for an unserviceable counterpart.
- g. **Repair:** The application of maintenance services (inspect, test, service, adjust, align, calibrate, or replace) or other maintenance actions (welding, grinding, riveting, straightening, facing, re-machining, or resurfacing) to restore serviceability to an item by correcting specific damage, fault, malfunction, or failure in a part, subassembly, module (component or assembly) end item or system.
- h. **Overhaul:** That maintenance effort (service/action) necessary to restore an item to a completely serviceable/operational condition as prescribed by maintenance standards (i.e. DMWR) in appropriate technical publications. Overhaul is normally the highest degree of maintenance performed by the Army. Overhaul does not normally return an item to like new condition.

3. **Column Entries:** Columns used in the MAC and entries for these columns are explained below:

- a. **Column 1:** Group Number: Column 1 lists group numbers, the purpose of which is to identify components, assemblies, subassemblies, and modules with the next higher assembly.
- b. **Column 2:** Component Assembly: Column 2 contains the noun names of components, assemblies, subassemblies, and modules for which maintenance is authorized.
- c. **Column 3:** Maintenance Functions: Column 3 lists the functions to be performed on the item listed in Column 2.

- d. Column 4: Maintenance Category: Column 4 specifies, by the listing of a "work time": figure in the appropriate subcolumn(s) the lowest level of maintenance authorized to perform the function listed in Column 3. This figure represents the active time required to perform the maintenance function at the indicated category of maintenance. If the number or complexity of the tasks within the listed maintenance function vary at different maintenance categories, appropriate "work time" figures will be shown for each category. The number of man-hours specified by the "work time" figure represents the average time required to restore an item (assembly, subassembly, component, module, and item, or system) to a serviceable condition under typical field operating conditions. This time includes preparation time, troubleshooting time and quality assurance/quality control time in addition to the time required to perform the specific tasks identified for the maintenance functions authorized in the MAC.

Section II. MAINTENANCE ALLOCATION CHART

GROUP NUMBER	COMPONENT ASSEMBLY	MAINTENANCE FUNCTION	MAINTENANCE LEVEL					TOOLS AND EQUIP	REMARKS
			UNIT		INTERMEDIATE DEPOT				
			C	O	F	H	D		
7411	Clamshell Assembly	Inspect Replace Repair	0.3	1.5	6.0				
7411	Bowl Assembly Bowl/Brackets	Inspect Replace	0.2		8.0 6.0				
	Repair Lip	Inspect	0.3		6.0 4.0				
	Replace Teeth	Inspect Replace	0.2	3.0					
	Bushings	Inspect Service Replace	0.5	0.5	4.0				
7411	Wire Rope, Sockets/Wedges Wire Rope	Inspect Replace	0.2	1.0					
	Sockets/Wedges	Inspect Replace	0.2	1.0					
7411	Lower Block Assembly Closing Sheaves	Inspect Replace Repair	0.2		6.0 4.0				
	Counterweight	Inspect Replace Repair	0.2	6.0 4.0					
7411	Head Assembly Arms	Inspect Replace Repair	0.2		6.0 4.0				
	Rollers	Inspect Replace Repair	0.2	2.0 2.0					
<p>MAINTENANCE LEVELS: C - OPERATOR/CREW F - INTERMEDIATE DIRECT SUPPORT D - DEPOT O - ORGANIZATIONAL H - INTERMEDIATE GENERAL SUPPORT</p>									

STA FORM 668-1
1 OCT 85

PREVIOUS EDITION IS OBSOLETE.

APPENDIX A

1. **SPECIAL TOOLS AND TEST SETS:** None
2. **COMMON TOOLS AND TEST SETS:** See Tool List, page 42.
3. **SPECIAL TMDE AND TEST SETS:** None
4. **COMMON TMDE AND TEST SETS:** None
5. **SPECIAL PURPOSE KITS:** None

APPENDIX B**OPERATOR/CREW
PREVENTIVE MAINTENANCE CHECKS AND SERVICES (PMCS)****GENERAL**

Your Preventive Maintenance Checks and Services table lists the inspection and care of your equipment required to keep it in good operating condition.

OPERATOR/CREW PREVENTIVE MAINTENANCE CHECKS AND SERVICES

1. The number column of your PMCS is the source for the number used on DA Form 2404.
2. The interval column of your PMCS table tells you when to do certain check or service.
 - a. Before you operate, always keep in mind the CAUTIONS and WARNINGS. Perform your before (B) PMCS.
 - b. While you operate, always keep in mind the CAUTIONS and WARNING. Perform your during (D) PMCS.
 - c. After your operate, be sure to perform your after (A) PMCS.
 - d. Do your weekly (W) PMCS once a week.
 - e. Do your monthly (M) PMCS once a month.
3. The procedure column of your PMCS table tells you how to do the required checks and services. Carefully follow these instructions. If you do not have the tools, or if the procedure tells you to, contact unit maintenance.
4. If your equipment does not perform as required, refer to the manual troubleshooting section for possible problems. Report any malfunctions or failures on the proper DA Form 2404 or refer to DA Pamphlet 738-750.

NOTE

The terms ready/available and mission capable refer to the same status: Equipment is on hand and is able to perform all its combat missions without further endangering the lives of the crew or operators in the combat environment (See DA Pamphlet 738-750).
5. Equipment is not ready/available if: column. This column tells you when and why your equipment cannot be used.
6. Always do your PMCS in the same order so it gets to be a habit. Once you've had some practice, you'll spot anything wrong in a hurry.
7. When you do your PMCS, take along a rag or two.
8. While performing PMCS, observe CAUTIONS and WARNINGS preceding those operations which could endanger your safety or result in damage to the equipment.

OPERATOR/CREW PREVENTIVE MAINTENANCE CHECKS AND SERVICES							
ITEM NO	INTERVAL					ITEM TO BE INSPECTED PROCEDURE: CHECK FOR AND HAVE REPAIRED, FILLED, OR ADJUSTED AS NEEDED	EQUIPMENT IS NOT READY/AVAILABLE IF:
	B	D	A	W	M		
1						<p>NOTE: Perform weekly as well as before PMCS if:</p> <ul style="list-style-type: none"> a. You are the assigned operator, but have not operated the equipment in the past week. b. You are operating the equipment for the first time. <p style="text-align: center;"><u>WARNING</u></p> <p>To avoid injury/death to personnel, or damage to equipment, do not run the crane or carrier engine when performing before operations PMCS. Do not get under, on or in the bucket when performing PMCS.</p> <p>General: Make the following walk around checks:</p> <ul style="list-style-type: none"> a. Check for loose/missing nuts, bolts and cotter pins. b. Check for proper installation of cable clamps, the "U" bolt must be installed over the deadend (loose end) of the cable. The saddle and nuts go on the live ends of the cable. <p>NOTE: Prior to full operation, make 4-5 lifts and dumps with the bucket. Set the bucket on the ground. Stop operations. Insure sockets, wedges and clamps are secure. Check cable for cuts and proper seating in the pulley grooves.</p>	

STA FORM 666
1 NOV 83

OPERATOR/CREW PREVENTIVE MAINTENANCE CHECKS AND SERVICES							
		B - BEFORE	D - DURING	A - AFTER	W - WEEKLY	M - MONTHLY	
ITEM NO	INTERVAL					ITEM TO BE INSPECTED PROCEDURE: CHECK FOR AND HAVE REPAIRED, FILLED, OR ADJUSTED AS NEEDED	EQUIPMENT IS NOT READY/AVAILABLE IF:
	B	D	A	W	M		
2	o					<u>Wire Rope (Cable)</u> a. Visually Check for crushed, kinked, birdcaged, worn or broken cable/wires.	Six broken wires in one lay or pitch. Three broken wires in one strand in one lay or pitch. Kinked, crushed, birdcaged or heat damaged wires.
	o					<u>Clamshell Bucket</u> a. Check rollers for free movement. b. Check for cracked welds. c. Check for bent arms/brackets.	Any weld cracked
	o					<u>Lubrication</u> a. Lubricate all lube points IAW the manufacturers manual. b. In water operations, lube every 4 hours of operation.	

STA FORM 666
1 NOV 83

OPERATOR/CREW PREVENTIVE MAINTENANCE CHECKS AND SERVICES							
B-4							
		B - BEFORE	D - DURING	A - AFTER	W - WEEKLY	M - MONTHLY	
ITEM NO	INTERVAL					ITEM TO BE INSPECTED PROCEDURE: CHECK FOR AND HAVE REPAIRED, FILLED, OR ADJUSTED AS NEEDED	EQUIPMENT IS NOT READY/AVAILABLE IF:
	B	D	A	W	M		
5	0					<p><u>Socket/Wedges</u></p> <p>a. Check for a loose wedge in the socket.</p> <p>b. Check for split/cracked socket.</p> <p style="text-align: center;">WARNING</p> <p style="text-align: center;">Do not touch sheave. Sharp edge may cause injury.</p>	Socket is split/cracked.
6	0					<p><u>Sheaves</u></p> <p>Visually check the outside edge of the rope groove for a sharp edge.</p>	Any sheave edge sharp enough to show evidence of cutting the cable.
7	0					<p><u>Teeth</u></p> <p>a. Check for missing teeth.</p> <p>b. Check for chipped/broken teeth.</p>	Two or more missing teeth.

STA FORM 666
1 NOV 83

APPENDIX B**UNIT
PREVENTIVE MAINTENANCE CHECKS AND SERVICES (PMCS)****GENERAL**

To make sure that your equipment is ready for operation at all times, inspect it systematically so you can discover any defects and have them corrected before they result in serious damage or failure. The charts on the next few pages contain your unit PMCS. The item numbers indicate the sequence of minimum inspection requirements. If you're operating the vehicle and notice something wrong which could damage the equipment if you continue operation, stop operation immediately.

Record all deficiencies and shortcomings, along with the corrective action taken, on DA Form 2404. The Item Number column is the source for the numbers used on the TM Number column on DA Form 2404.

UNIT PREVENTIVE MAINTENANCE CHECKS AND SERVICES

1. The item numbers of the table indicate the sequence of the PMCS. Perform at the intervals shown below:
 - a. Do your (Q) PREVENTIVE MAINTENANCE quarterly. (every three months).
 - b. Do your (S) PREVENTIVE MAINTENANCE semi-annually (every six months).
2. If something doesn't work, troubleshoot it according to the instructions in this manual or the commercial manual or notify your supervisor.
3. Always do your preventive maintenance in the same order, so it gets to be a habit. Once you've had some practice, you'll spot anything wrong in a hurry.
4. If anything looks wrong and you can't fix it, write it down on your DA Form 2404. If you find something seriously wrong, report it to direct support as soon as possible.

WARNING

Dry cleaning solvent P-D-680 is toxic and flammable. Wear protective goggles and gloves and use only in well ventilated areas. Avoid contact with skin, eyes and clothes and don't breathe vapors. Do not use near open flame or excessive heat. The flash point is 100 F - 138 F (38 C - 59 C). If you become dizzy while using cleaning solvent, get fresh air immediately and get medical aid. If contact with eyes is made, wash your eyes with water and get medical aid immediately.

WARNING

Compressed air, used for cleaning purposes will not exceed 30 psi. Use only with effective chip guarding and personnel protective equipment (goggles/shield/gloves, etc.).

- a. Keep it clean: Dirt, grease, oil and debris only get in the way and may cover up a serious problem. Clean as you work and as needed. Use dry cleaning solvent (P-D-680) to clean metal surfaces. Use soap and water when you clean rubber or plastic material.

- b. Bolts, nuts and screws: Check that they are not loose, missing, bent or broken. You can't try them all with a tool, of course, but look for chipped paint, bare metal or rust around bolt heads. Tighten any bolt, nut, or screw that you find loose.
- c. Welds: Look for loose or chipped paint, rust or gaps where parts are welded together. If you find a bad weld, report it to intermediate direct support.

UNIT PREVENTIVE MAINTENANCE CHECKS AND SERVICES

M-MONTHLY Q-QUARTERLY S-SEMIANNUALLY A-ANNUALLY B-BIENNIALLY H-HOURS MI-MILES

ITEM NO.	INTERVAL							ITEM TO BE INSPECTED PROCEDURE: CHECK FOR AND HAVE REPAIRED, FILLED, OR ADJUSTED AS NEEDED PERFORM ALL OPERATOR PMCS FIRST
	M	Q	S	A	B	H	MI	
1			o					<u>Socket and Link</u> : Check for split/worn socket or link.
2			o					<u>Rollers</u> : Use a pry bar and pry the rollers apart. Check for movement of 3/8 inch or more.
3			o					<u>Upper Arm Pin</u> : Rotate the pin 180° (degrees). (Page 16 in the manufacturer's manual). Check for worn bushings (see Page 16, manufacturer's manual.)
4			o					<u>Upper Arm Bar</u> : Check for bent bars. Replace any bent bar (Page 18, manufacturer's manual).
5			o					<u>Corner Bracket</u> : Rotate the pins 180° (degrees). Inspect the bushings for wear. (Page 19, manufacturer's manual). WARNING!!! DO NOT TOUCH SHEAVES, SHARP EDGE MAY CAUSE INJURY.
6			o					<u>Sheaves</u> : Use a prybar and lift the first sheave the rope passes around. Replace bushings and pins on all sheaves showing excessive freeplay. Check for a sharp edge on the sheaves. (PAGE 24, manufacturer's manual.)
7			o					<u>Lip and Bowl</u> : Check for cracks, dents, holes and wear on the lips (Page 25, manufacturer's manual).
8			o					<u>Teeth</u> : Check for wear in excess of two inches. Teeth must be at least 15 inches long. Measure end to end. Replace worn, damaged teeth. (Page 28, manufacturer's manual).
9			o					<u>Main Shaft</u> : Check for sideplay, 1/8" sideplay or more is excessive. Install shims to remove sideplay. (Page 21, manufacturer's manual). Every 600 operating hours rotate the shaft 180° (degrees). (Page 22-23 manufacturer's manual). Every 1000 operating hours measure shaft and hinge bushings for wear. Replace worn parts (Page 23, manufacturer's manual).

B-7/(B-8 blank)

B-7/(B-8 blank)

APPENDIX C

ADDITIONAL AUTHORIZED ITEMS
(ITEMS TROOP INSTALLED)

SMR CODE	NSN	DESCRIPTION	U/M	QTY/ AUTH
PAOZZ	4240-00-052-3776	Goggles, Industrial GSA	EA	1
PAOZZ	4210-00-555-8837	Extinguisher, Fire	EA	2
PAOZZ	7520-00-559-9618	Bag, Pamphlet	EA	1

BASIC ISSUE ITEMS

None

C-1/(C-2 blank)

APPENDIX D

MAINTENANCE AND OPERATING SUPPLY LIST

BUCKET, CLAMSHELL
 INTERGY, INC.
 Model 34GP S
 MFR Part No. 104422 (9Y918)
 NSN 3815-01-249-4092
 Serial No. Range 1186104422-1 to 1186104422-234
 Date: Jul 87

MFR PIN COMPONENT APPLICATION	OR NSN	QTYREO DESCRIPTION	QTY REQ F/INITIAL OPN	F/8 HRS OPN
PIVOT POINTS	9150-00-188-9858	OIL, LUBRICATING OE/HDO30	1 Qt	Var
GREASE	9150-00-190-0907	GREASE, GAA	35 LB.	Var

D-1/(D-2 blank)

APPENDIX E

DA EQUIPMENT PUBLICATIONS

NOMENCLATURE	EQUIPMENT PUBLICATION NUMBER	DATE AVAILABLE
Department of the Army Authenticated Commercial Edited Manuals:	To be published	
Operator's Manual	Overpacked with equipment	
Service and Repair Manual	Overpacked with equipment	
Parts Manual	Overpacked with equipment	

OTHER THAN OFFICIAL DA EQUIPMENT PUBLICATIONS

NOMENCLATURE	EQUIPMENT PUBLICATION NUMBER OR TYPE	DATE AVAILABLE	SOURCE OF SUPPLY
Commercial Manual	Manufacturer's Operating Maintenance Manual and		
Operator's Guide	Supplemental Operating, Maintenance and Repair Parts		Current
Lubrication and Maintenance Guide	Instructions (SOMARPI)		Current
Parts Book			Current

E-1/(E-2 blank)

APPENDIX F

LUBRICATION ORDER

BUCKET, CLAMSHELL, 3/4 CU. YD., MODEL 34GP S

REFERENCE: Manufacturers Commercial Manual

Hard time intervals and the related man-hour times are based on normal operation. The man-hour time specified is the time you need to do all the services prescribed for a particular interval. Change the hard time interval if your lubricants are contaminated or if you are operating the equipment under adverse operating conditions, including longer-than-usual operating hours. The hard time interval may be extended during periods of low activity. If extended, adequate preservation precautions must be taken.

WARNING

Dry cleaning fluid is flammable. Do not use near a flame or excessive heat. Use only with adequate ventilation. Avoid prolonged breathing of vapors and minimize skin contact.

*The time specified is the time required to perform all services at the particular interval.

Clean parts or fittings with dry cleaning solvent (SD). Type II or equivalent. Dry before lubricating. Dotted arrow shafts indicate lubrication on both sides of equipment. A dotted circle indicates a drain below. Relubricate all items found contaminated after fording or washing.

The lowest level of maintenance authorized to lubricate a point is indicated by one of the following symbols as appropriate: Operator/Crew (C); and Organizational Maintenance (O).

*TOTAL MAN-HOURS

INTERVAL	MAN-HOURS
8	0.5
4	0.5

(See NOTE 1)

NOTES:

1. Lube every 4 hours when used in water operations.
2. Lube at pivot points prior to operation and every 4 hours in water operations. (4-6 squirts).
3. LUBRICANTS. The following is a list of lubricants with military symbols and applicable specification numbers:

OE/HDO MIL-L-2104

GAA MIL-G-10924

OEA MIL-L-46167

CLAMSHELL LUBRICATION CHART

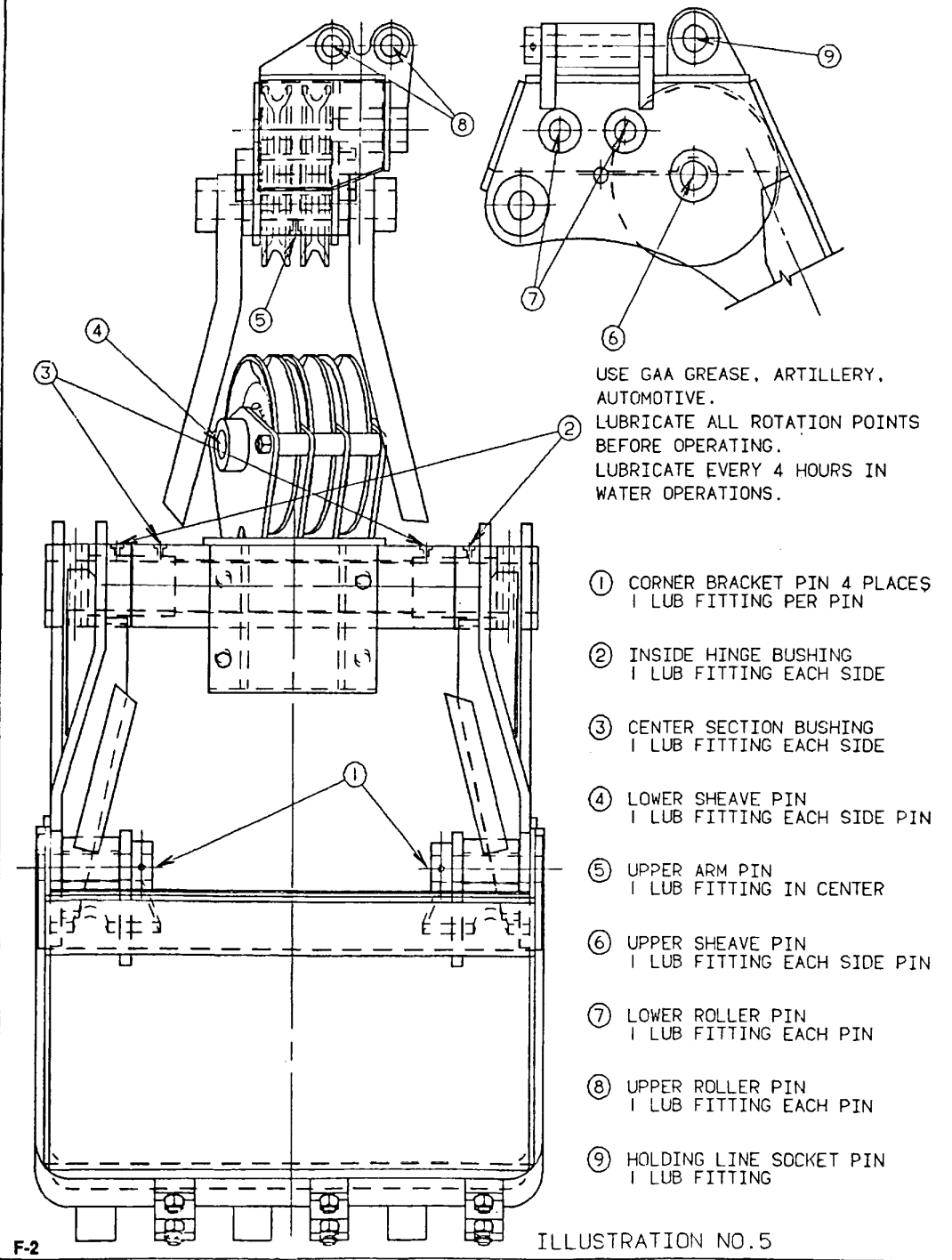

-KEY-					
LUBRICANTS	CAPACITY	EXPECTED TEMPERATURES			INTERVALS
		Above + 60°F (Above +15°C)	+59°F to 15°F (+15°C to 25°C)	-14°F to 65°F (-25°C to -65°C)	
OE/HDO Lubricating Oil, Internal Combustion Engine, Tactical Service		30	30	FOR ARTIC OPERATION REFER TO FM 9-207	See note 2
OEA- Lubricating Oil, Internal Combustion, Arctic					Intervals given are in hours-of normal operation, UNLESS OTHERWISE SPECIFIED
GAA- Grease Automotive and Artillery		ALL TEMPERATURES			See Note 1
See NOTES, page F-1					

F-3/(F-4 blank)

F-3/(F-4 blank)

APPENDIX G

SAMPLE FORMAT - DA FORM 2765 PART NUMBER REQUEST

(CONUS Requester)

DA FORM 2765-1 1 MAR 68	DOC IDENT	ROUT IDENT	FSC	NIN	ADD	UNIT	QUANTITY	REQ	DATE	SERIAL	SUPPLEMENTARY	FUND	DISTR	PROJECT	PR	REQ DEL	ADV
SEND TO:	REQ IS FROM:	STOCK NUMBER	NIN	ADD	UNIT OF ISSUE	QUANTITY	EA	00001	9Y 918 104 42								
EIC Code - leave blank if not in DA Pam 738-750	BUCKET, CLAMSHELL 3/4 CU YD	Intergy Corp. Commercial Parts Manual	DSS Project Code (See Appendix H)														

(CONUS)

DA FORM 2765-1 1 MAR 68	DOC IDENT	ROUT IDENT	FSC	NIN	ADD	UNIT	QUANTITY	REQ	DATE	SERIAL	SUPPLEMENTARY	FUND	DISTR	PROJECT	PR	REQ DEL	ADV
SEND TO:	REQ IS FROM:	STOCK NUMBER	NIN	ADD	UNIT OF ISSUE	QUANTITY	EA	00001	9Y 918 104 42 22								
EIC Code - Leave blank if not in DA Pam 738-750	BUCKET, CLAMSHELL 3/4 CU YD	Intergy Corp. Commercial Parts Manual															

G-1/(G-2 blank)

APPENDIX H

DSS PROJECT CODES

Geographic Location	ASL	NSL
CONUS (Eastern US)	XDC	NSC
CONUS (Central US)	XDA	NSA
CONUS (Western US)	XDB	NSB

Designated distribution depot support areas.

H-1/(H-2 blank)

APPENDIX I

SAMPLE FORMAT - MILSTRIP REQUISITION (NSN)

Card Column

Description of Data

Mandatory Entry for CCE

- 1-3 Document Identifier Code
- 4-6 Routing Identifier Code
- 7 Media/Status Code
- 8-22 NSN
- 23-24 Unit of Issue
- 25-29 Quantity
- 30-43 Document Number
- 44 Demand Code
- 45-50 Supplementary Address
- 51 Signal Code
- 52-53 Fund Code
- 54-46 Distribution Code CC-54
- 57-59 Project Code
- 60-61 Priority Code
- 62-64 Required Delivery Date
- 65-66 Advice Code

- A0A - CONUS
- A01 - CONUS

CC-55-56

"F" for CONUS;
see AR 725-50 for
OCONUS
*Weapon System
DSS Code

I-1/(1-2 blank)

APPENDIX J

SAMPLE FORMAT - MILSTRIPO REQUISITION FOR (NON-NSN)

Card Column	Description of Data	Mandatory Entry for CCE
1-3	Document Identifier Code	AOB - CONUS A02 - OCONUS
4-6	Routing Identifier Code	Always S9C
7	Media/Status Code	
8-22	FSCM and Part Number	
23-24	Unit of Issue	
25-29	Quantity	
30-43	Document Number	
44	Demand Code	
45-50	Supplementary Address	
51	Signal Code	
52-53	Fund Code	
54-56	Distribution Code CC-54	"F" for CONUS, see AR 725-50 for OCONUS *Weapon System Code
	CC-55-56	
57-59	Project Code	DSS Code (CONUS) "JZC" (OCONUS)
60-61	Priority Code	
62-64	Required Delivery Date	
65-66	Advice Code	

*Weapons System Designator Code for Crane is 7Y

APPENDIX (Continued)

<u>CARD COLUMN</u>	<u>DESCRIPTION OF DATA</u>	<u>MANDATORY ENTRY</u>
67-69	Blank	
70	Identification code applicable to entry in cc 71-80 A - Technical Order or Technical Manual B - End Item Identification C - Noun Description D - Drawing or Specification Number	
71-80	Reference Identification	Identification of reference specified in CC 70

APPENDIX K

SAMPLE FORMAT - MILSTRIP REQUISITION (NON-NSN) (MANUAL)

DOCUMENT IDENTIFIER							ROUTING IDENTIFIER							M & S							MANUFACTURER'S CODE AND PART NUMBER *															UNIT OF ISSUE		QUANTITY										DOCUMENT NUMBER											
																																																REQUISITIONER				DATE				SERIAL			
1	2	3	4	5	6	7	8	9	10	11	12	13	14	15	16	17	18	19	20	21	22	23	24	25	26	27	28	29	30	31	32	33	34	35	36	37	38	39	40	41	42	43																	
DEMAND		SUPPLEMENTARY ADDRESS			SIGNAL		FUND CODE		DISTRIBUTION CODE		PRQ. CODE		PRIOR. CODE		RE-REQUIRED DELIVERY DATE		ADVICE CODE		BLANK								REJECT CODE (FOR USE BY SUPPLY SOURCE ONLY)																																
44	45	46	47	48	49	50	51	52	53	54	55	56	57	58	59	60	61	62	63	64	65	66	67	68	69	70	71	72	73	74	75	76	77	78	79	80	81	82	83	84	85	86																	
																																									65	66																	
IDENTIFICATION DATA																																																											
* 1. MANUFACTURER'S CODE & PART NO. (When they exceed Card Columns 8 thru 22)																		2. MANUFACTURER'S NAME																																									
3. MANUFACTURER'S CATALOG IDENTIFICATION AND DATE																				4. TECHNICAL ORDER NUMBER																																							
5. TECHNICAL MANUAL NUMBER																		6. NAME OF ITEM REQUESTED																																									
7. DESCRIPTION OF ITEM REQUESTED																				7a. COLOR																																							
																				7b. SIZE																																							
8. END ITEM APPLICATION AND SOURCE OF SUPPLY																																																											
8a. MAKE															8b. MODEL NUMBER										8c. SERIES										8d. SERIAL NUMBER																								
9. REQUISITIONER (Clear Text Name and Address)																				10. REMARKS																																							

DD FORM 1348-6 1 APR 77

EDITION OF 1 MAR 74 MAY BE USED UNTIL EXHAUSTED

NON-NSN REQUISITION (MANUAL)

APPENDIX K (CONTINUED)

INSTRUCTIONS

This form will only be used in those cases where the manufacturer's code and part number exceed the spaces allocated in card columns 8-22 of the requisition.

<u>CARD COLUMN</u>	<u>DESCRIPTION OF DATA</u>	<u>MANDATORY ENTRY FOR CCE</u>
1-3	Document Identifier Code	A0E - CONUS
4-6	Routing Identifier Code	A05 - OVERSEAS
7	Media Status Code	Always 39C
8-22	FSCM and Part Number	Leave Blank Enter in Block 1 under Identification Data
23-24	Unit of Issue	
25-29	Quantity	
30-34	Document Number	
44	Demand Code	
45-50	Supplementary Address	
51	Signal Code	
52-53	Fund Code	
54-56	Distribution Code CC 54	"F" for CONUS. (See AR 725-50 for over- seas.)
	CC 55-56	Weapon System Code
57-59	Project Code	DSS CODE (CONUS) "JZC" (OCONUS)
60-61	Priority Code	
62-64	Required Delivery Date	
65-66	Advice Code	
67-80		Blank

IDENTIFICATION DATA - Lower half of DD Form 1348-6, complete blocks 1 thru 9.

APPENDIX L

REQUISITION FORM T

NON-NSN REQUISITION FORMAT

CARD COLUMN	DESCRIPTION	ENTRY	
		CONUS	OCONUS
1-3	Document Identifier Code	AOB	AO2
4-6	Routing Identifier Code	S9C	S9C
8-22	Part Number	Enter the Federal Supply Code for the Manufacturer, followed by the part number.	
54-56	Distribution Code:		
54	Control Activity	F	AR 725-50
55-56	Weapons System Designator Code		
57-59	Project Code	BGW	JZC

L-1/(L-2 blank)

APPENDIX M

NSN FORMAT

CARD COLUMN	DESCRIPTION	ENTRY	
		CONUS	OCONUS
1-3	Document Identifier Code	A0A	A01
8-22	National Stock Number	Enter the Applicable 13 Digit NSN	
54-56	Distribution Code	Same as Table 1, above.	
57-59	Project Code	Not Required	

M-1/(M-2 blank)

**APPENDIX N
REPAIR PARTS AND SPECIAL TOOLS LISTS**

Section 1. INTRODUCTION

N-1. SCOPE.

This RPSTL lists and authorizes spares and repair parts; special tools; special test, measurement, and diagnostic equipment (TMDE); and other special support equipment required for performance of unit and direct support maintenance of the Clamshell Bucket. It authorizes the requisitioning, issue, and disposition of spares, repair parts and special tools as indicated by the source, maintenance and recoverability (SMR) codes.

N-2. GENERAL.

In addition to Section I, Introduction, this Repair Parts and Special Tools List is divided into the following sections:

a. **Section II. Repair Parts List.** A list of spares and repair parts authorized by this RPSTL for use in the performance of maintenance. The list also includes parts which must be removed for replacement of the authorized parts. Parts lists are composed of functional groups in ascending alphanumeric sequence, with the parts in each group listed in ascending figure and item number sequence. Bulk materials are listed in item name sequence. Repair parts kits are listed separately in their own functional group within Section II. Repair parts for reparable special tools are also listed in this section. Items listed are shown on the associated illustration(s)/figure(s).

b. **Section III. Special Tools List.** A list of special tools, special TMDE, and other special support equipment authorized by this RPSTL [as indicated by Basis of Issue (BOI) information in the DESCRIPTION AND USABLE ON CODE column] for the performance of maintenance.

c. **Section IV. Cross-reference Indexes.** A list, in National Item Identification Number (NIIN) sequence, of all National stock numbered items appearing in the listing, followed by a list in alphanumeric sequence of all part numbers appearing in the listings. National stock numbers and part numbers are cross-referenced to each illustration/figure and item number appearance. The figure and item number index lists figure and item numbers in alphanumeric sequence and cross-references NSN, CAGE, and part numbers.

N-3. EXPLANATION OF COLUMNS (SECTIONS II AND III).

a. **ITEM NO. [Column (1)].** Indicates the number used to identify items called out in the illustration.

b. **SMR CODE [Column (2)].** The Source, Maintenance, and Recoverability (SMR) code is a 5-position code containing supply/requisitioning information, maintenance category authorization criteria, and disposition instruction, as shown in the following breakout:

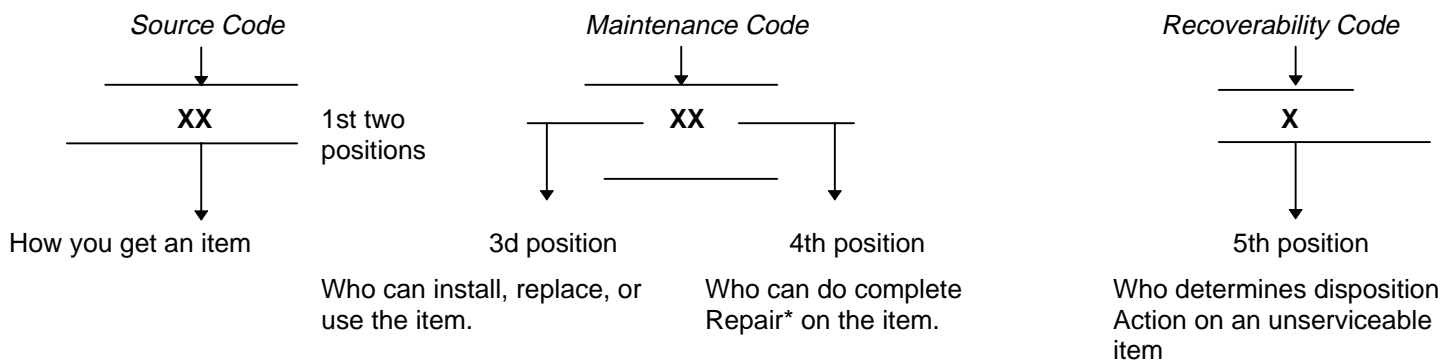

**Complete Repair:* Maintenance capacity, capability, and authority to perform all corrective maintenance tasks of the "Repair" function in a use/user environment in order to restore serviceability to a failed item.

N-3. EXPLANATION OF COLUMNS (SECTIONS II AND III) (Con't).

(1) Source Code. The source code tells you how to get an item needed for maintenance, repair, or overhaul of an end item/equipment. Explanations of source codes follow:

Code	Application/Explanation
PA PB PC** PD PE PF PG	<p>Stocked items; use the applicable NSN to request/requisition items with these source. They are authorized to the category indicated by the code entered in the 3d position of the SMR code.</p> <p>** Items coded PC are subject to deterioration.</p>
KD KF KB	<p>Items with these codes are not to be requested/requisitioned individually. They are part of a kit which is authorized to the maintenance category indicated in the 3d position of the SMR code. The complete kit must be requisitioned and applied.</p>
MO - Made at UM/AVUM Level MF - Made at DS/AVUM Level MH - Made at GS Level MD - Made at Depot	<p>Items with these codes are not to be requested/requisitioned individually. They must be made from bulk materiel which is identified by the part number in the DESCRIPTION AND USABLE ON CODE (UOC) column and listed in the bulk materiel group of the repair parts. If the item is authorized to you by the 3d position code of the SMR code, but the source code indicates it is made at a higher level, order the item from the higher level of maintenance.</p>
AO - Assembled by UM/AVUM Level AF - Assembled by DS/AVUM Level AH - Assembled by GS Level AD - Assembled at Depot	<p>Items with these codes are not to be requested/requisitioned individually. The parts that make up the assembled item must be requisitioned or fabricated and assembled at the level of maintenance. Indicted by the source code. If the 3d position code of the SMR code authorizes you to replace the item, but the source code indicates that the item is assembled at a higher level, order the item from the higher level of maintenance.</p>

NOTE

Cannibalization or controlled exchange, when authorized, may be used as a source of supply for items with the above source codes, except for those source coded 'XA.'

XA - DO NOT requisition an "XA"-coded item. Order its next higher assembly.

XB - If an "XB" item is not available from salvage, order it using the CAGE and part number given.

N-3. EXPLANATION OF COLUMNS (SECTIONS II AND III) (Con't).

XC - Installation drawing, diagram, instruction sheet, field service drawing, that is identified by manufacturer's part number.
 XD - Item is not stocked. Order an "XD"-coded item through normal supply channels using the CAGE and part number given, if no NSN is available.

(2) Maintenance Code. Maintenance codes tell you the level(s) of maintenance authorized to use and repair support items. The maintenance codes are entered in the third and fourth positions of the SMR code as follows:

(a) The maintenance code entered in the third position tells you the lowest maintenance level authorized to remove, replace, and use an item. The maintenance code entered in the third position will indicate authorization to one of the following levels of maintenance.

Code	Application/Explanation
C	-Crew or operator maintenance done within unit maintenance or aviation unit maintenance.
O	-Unit maintenance or aviation unit can remove, replace, and use the item.
F	-Direct support or aviation intermediate level can remove, replace, and use the item.
H	-General support level can remove, replace, and use the item.
L	-Specialized repair activity can remove, replace, and use the item.
D	-Depot level can remove, replace, and use the item.

NOTE

Some limited repair may be done on the item at a lower level of maintenance, if authorized by the Maintenance Allocation Chart (MAC) and SMR codes.

(b) The maintenance code entered in the fourth position tells whether or not the item is to be repaired and identifies the lowest maintenance level with the capability to do complete repair (i.e., perform all authorized "Repair" functions). This position will contain one of the following maintenance codes:

Code	Application/Explanation
O	-Unit maintenance or aviation unit is the lowest level that can do complete repair of the item.
F	-Direct support or aviation intermediate is the lowest level than can do complete repair of the item.
H	- General support is the lowest level that can do complete repair of the item.
L	- Specialized repair activity is the lowest level that can do complete repair of the item.
D	- Depot is the lowest level that can do complete repair of the item.
Z	- Nonreparable. No repair is authorized.
B	- No repair is authorized. (No parts or special tools are authorized for the maintenance of a "B"-coded item.) However, the item may be reconditioned by adjusting, lubricating, etc., at the user level.

**Change 1
 N-3**

N-3. EXPLANATION OF COLUMNS (SECTIONS II AND III) (Con't).

(3) Recoverability Code. Recoverability codes are assigned to items to indicate the disposition action on unserviceable items. The recoverability code is entered in the fifth position of the SMR code as follows:

Code	Application/Explanation
Z	-Nonreparable item. When unserviceable, condemn and dispose of the item at the level of maintenance shown in the 3d position of the SMR code.
O	-Reparable item. When uneconomically reparable, condemn and dispose of the item at unit maintenance or aviation unit level.
F	-Reparable item. When uneconomically reparable, condemn and dispose of the item at the direct support or aviation intermediate level.
H	-Reparable item. When uneconomically reparable, condemn and dispose of the item at the general support level.
D	-Reparable item. When beyond lower level repair capability, return to depot. Condemnation and disposal of item not authorized below depot level.
L	-Reparable item. Condemnation and disposal of item not authorized below specialized repair activity (SRA).
A	-Item requires special handling or condemnation procedures because of specific reasons (e.g., precious metal content, high dollar value, critical material, or hazardous material). Refer to appropriate manuals/directives for specific instructions.

- c. CAGEC [Column (3)]. The Commercial and Government Entity (CAGE) Code (C) is a 5-digit alphanumeric code which is used to identify the manufacturer, distributor, or Government agency, etc., that supplies the item.

NOTE

When you use an NSN to requisition an Item, the Item you receive may have a different part number from the part ordered.

- d. PART NUMBER [Column (4)]. Indicates the primary number used by the manufacturer (individual, company, firm, corporation, or Government activity), which controls the design and characteristics of the item by means of its engineering drawings, specifications standards, and inspection requirements to identify an item or range of items.
- e. DESCRIPTION AND USABLE ON CODE (UOC) [Column (5)]. This column includes the following information:
 - (1) The Federal item name and, when required, a minimum description to identify the item.
 - (2) Physical security classification. Not Applicable.
 - (3) Items that are included in kits and sets are listed below the name of the kit or set on Figure KIT
 - (4) Spare/repair parts that make up an assembled item are listed immediately following the assembled item line entry.
 - (5) Part numbers for bulk materials are referenced in this column in the line item entry for the item to be manufactured/fabricated.

N-3. EXPLANATION OF COLUMNS (SECTIONS II AND III) (Con't).

- (6) When the item is not used with all serial numbers of the same model, the effective serial numbers are shown on the last line(s) of the description (before UOC). Not Applicable.
 - (7) The usable on code, when applicable (see paragraph N-5, Special Information).
 - (8) In the Special Tools List section, the Basis of Issue (BOI) appears as the last line(s) in the entry for each special tool, special TMDE, and other special support equipment. When density of equipments supported exceeds density spread indicated in the Basis of Issue, the total authorization is increased proportionately.
 - (9) The statement "END OF FIGURE" appears just below the last item description in Column 5 for a given figure in both Section II and Section III.
- f. **QTY [Column (6)].** The QTY (quantity per figure) column indicates the quantity of the item used in the breakout shown on the illustration/figure, which is prepared for a functional group, subfunctional group, or an assembly. A "V" appearing in this column in lieu of a quantity indicates that the quantity is variable and the quantity may vary from application to application.

N-4. EXPLANATION OF COLUMNS (SECTION IV).**a. National Stock Number (NSN) Index.**

(1) **STOCK NUMBER** column. This column lists the NSN by National Item Identification Number (NIIN) sequence. The NIIN consists of the last nine digits of the NSN (i.e., NSN 5305-01-674-1467). When using this column to locate an item, ignore the first 4 digits of the NSN. However, the complete NSN should be used when ordering items by stock number.

(2) **FIG.** column. This column lists the number of the figure where the item is identified/located. The figures are in numerical order in Section II and Section III.

(3) **ITEM** column. The item number identifies the item associated with the figure listed in the adjacent FIG. column. This item is also identified by the NSN listed on the same line.

b. **Part Number Index.** Part numbers in this index are listed by part number in ascending alphanumeric sequence (i.e., vertical arrangement of letter and number combination which places the first letter or digit of each group in order A through Z, followed by the numbers 0 through 9 and each following letter or digit in like order).

(1) **CAGEC** column. The Commercial and Government Entity (CAGE) Code (C) is a 5-digit alphanumeric code used to identify the manufacturer, distributor, or Government agency, etc., that supplies the item.

(2) **PART NUMBER** column. Indicates the primary number used by the manufacturer (individual, firm, corporation, or Government activity), which controls the design and characteristics of the item by means of its engineering drawings, specifications standards and inspection requirements to identify an item or range of items.

(3) **STOCK NUMBER** column. This column lists the NSN for the associated part number and manufacturer identified in the PART NUMBER and CAGE columns to the left.

(4) **FIG.** column. This column lists the number of the figure where the item is identified/located in Section II and Section III.

(5) **ITEM** column. The item number is that number assigned to the item as it appears in the figure referenced in the adjacent figure number column.

N-4. SPECIAL INFORMATION (Con't).

c. Figure and Item Number Index.

(1) FIG. column. This column lists the number of the figure where the item is identified/located in Sections II and III.

(2) ITEM column. The item number is that number assigned to the item as it appears in the figure referenced in the adjacent figure number column.

(3) STOCK NUMBER column. This column lists the NSN for the item.

(4) CAGE column. The Commercial and Government Entity (CAGE) is a 5-digit alphanumeric code used to identify the manufacturer, distributor, or Government agency, etc., that supplies the item.

(5) PART NUMBER column. Indicates the primary number used by the manufacturer (individual, firm, corporation, or Government activity), which controls the design and characteristics of the item by means of its engineering drawings, specifications standards and inspection requirements to identify an item or range of items.

N-5. SPECIAL INFORMATION.

a. Usable On Code. The usable on code appears in the lower left corner of the Description column heading. Not Applicable.

b. Fabrication Instructions. Bulk materials required to manufacture items are listed in the Bulk Materiel Functional Group of this RPSTL. Not Applicable.

c. Assembly Instructions. Detailed assembly instructions for items source coded to be assembled from component spare/repair parts are found in TM 5-3815-225-13&P. Items that make up the assembly are listed immediately following the assembly item entry or reference is made to an applicable figure.

d. Kits. Line item entries for repair parts kits appear in group 9401 in Section II. Not Applicable.

a. Index Numbers. Items which have the word BULK in the FIG. column will have an index number shown in the item column. This Index number is a cross-reference between the National Stock Number/Part Number Index and the bulk materiel list in Section II.

N-6. HOW TO LOCATE REPAIR PARTS.

a. When National Stock Number or Part Number Is Not Known:

(1) First. Using the Table of Contents, determine the assembly group or subassembly group to which the item belongs. This is necessary since figures are prepared for assembly groups and subassembly groups, and listings are divided into the same groups.

(2) Second. Find the figure covering the assembly group or subassembly group to which the item belongs.

(3) Third. Identify the item on the figure and use the Figure and Item Number Index to find the NSN.

b. When National Stock Number or Part Number is Known:

(1) First. Using the National Stock Number or Part Number Index, find the pertinent National Stock Number or Part Number. The NSN Index is in National Item Identification Number (NIIN) sequence [see paragraph N-4.a(1)]. The part numbers in the Part Number Index are listed in ascending alphanumeric sequence (see paragraph N-4.b). Both indexes cross-reference you to the illustration/figure and item number of the item you are looking for.

(2) Second. Turn to the figure and item number, verify that the item is the one you're looking for, then locate the item number in the repair parts list for the figure.

N-7. ABBREVIATIONS.

For standard abbreviations see MIL-STD-12D, Military Standard Abbreviations for Use on Drawings, Specifications, Standards, and in Technical Documents.

Abbreviations	Explanation
NIIN	National Item Identification Number (consists of the last 9 digits of the NSN)
RPSTL	Repair Parts and Special Tools Lists

Change 1
N-7

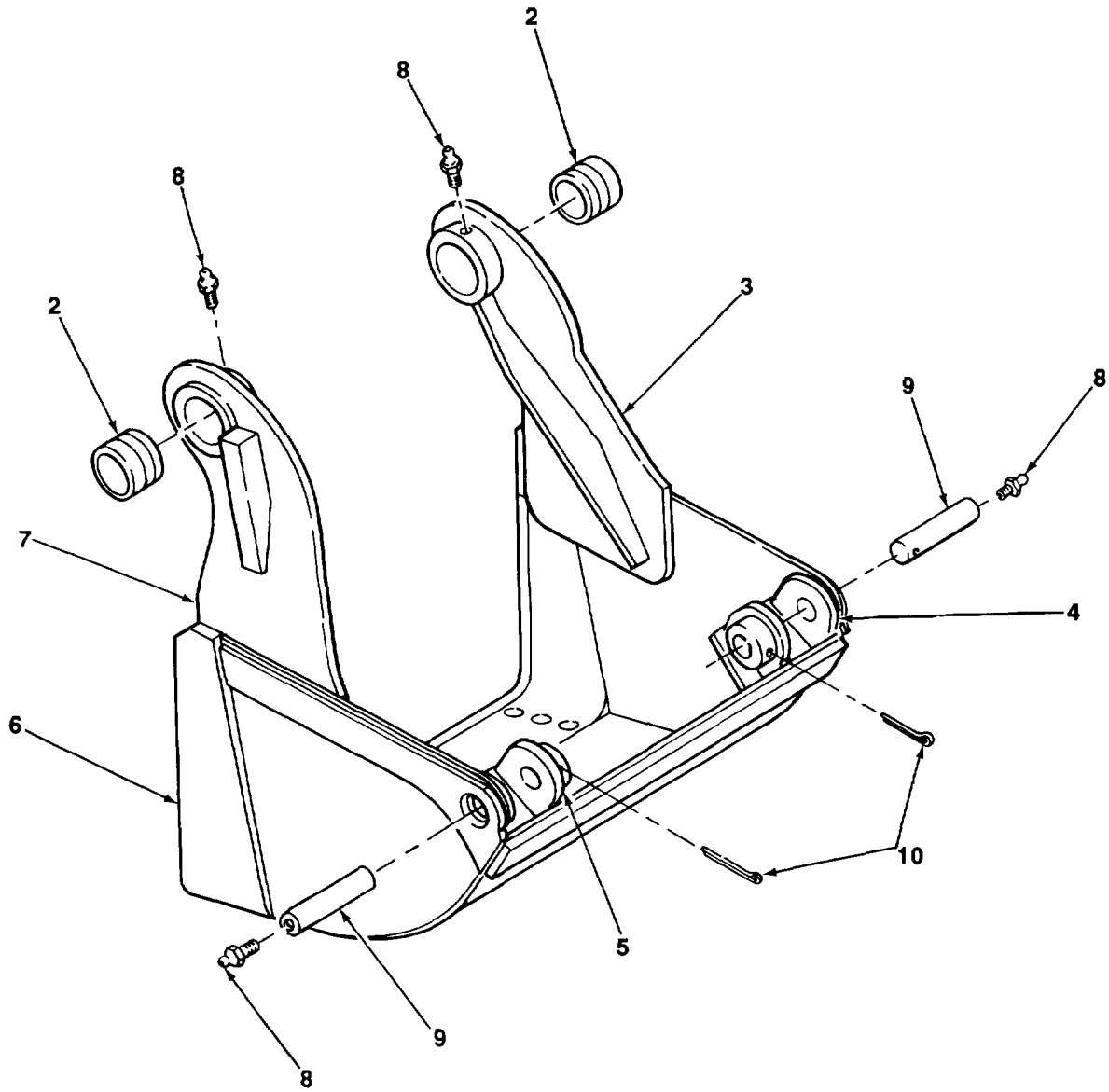
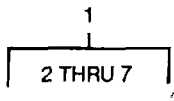

TA704546

FIGURE 1. BOWL ASSEMBLY (INSIDE HINGES).

SECTION II

TM5-3815-225-13&PC01

(1) ITEM NO	(2) SMR CODE	(3) CAGEC	(4) PART NUMBER	(5) DESCRIPTION AND USABLE ON CODES (UOC)	(6) QTY
GROUP 74 CRANES, SHOVELS AND EARTHMOVING EQUIPMENT COMPONENTS					
GROUP 7411 CRANE DRAGLINE OR CLAMSHELL ATTACHMENTS					
FIG* 1 BOWL ASSEMBLY (INSIDE HINGES)					
1	PBFFF	9Y918	107527	BOWL, CLAMSHELL	1
2	PAFZZ	9Y918	100837-1	BUSHING, SLEEVE.....	2
3	PFFZZ	9Y918	106470-2	INSOLE HINGE, CLAMSH	1
4	PFFZZ	9Y918	107525-2	BRACKET, EYE, ROTATIN.....	1
5	PFFZZ	9Y918	107525-1	BRACKET, EYE, ROTATIN.....	1
6	PFFZZ	9Y918	107524	LIP, CLAMSHELL	1
7	PFFZZ	9Y918	106470-1	INSIDE HINGE, CLAMSH.....	1
8	PFOZZ	96906	MS15003-1	FITTING, LUBRICATION.....	4
9	PAOZZ	9Y918	107528	PIN, STRAIGHT, HEADLED.....	2
10	PFOZZ	96906	MS24665-872	PIN, COTTER	2

END OF FIGURE

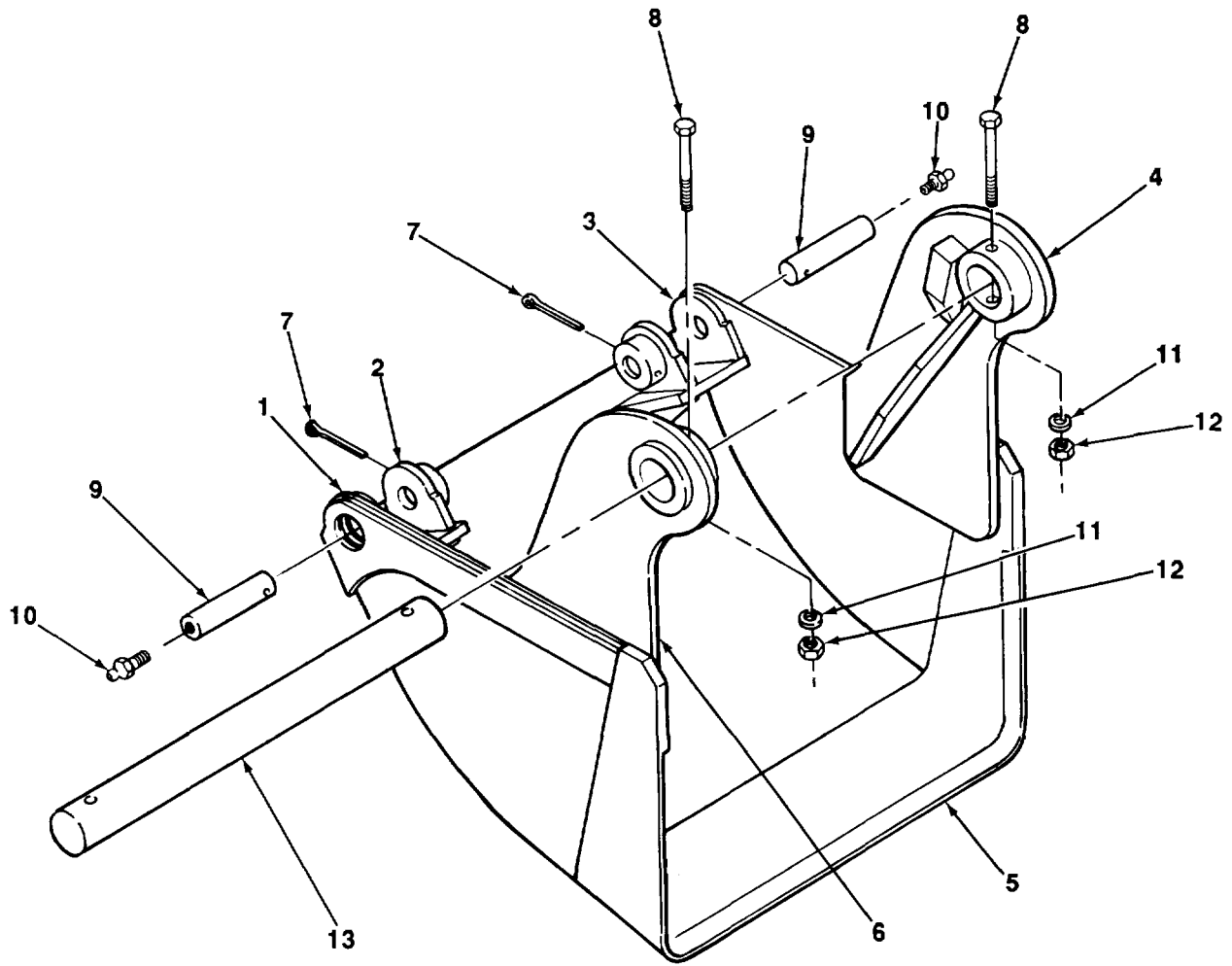
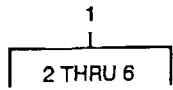

TA704547

FIGURE 2. BOWL ASSEMBLY (OUTSIDE HINGES).

SECTION II

TM5-3815-225-13&PC01

(1) ITEM NO	(2) SMR CODE	(3) CAGEC	(4) PART NUMBER	(5) DESCRIPTION AND USABLE ON CODES (UOC)	(6) QTY
				GROUP 7411 CRANE DRAGLINE OR CLAMSHELL ATTACHMENTS	
				FIG. 2 BOWL ASSEMBLY (OUTSIDE HINGES)	
1	PBFFF	9Y918	107526	BUCKET, CLAMSHELL	1
2	PFFZZ	9Y918	107525-2	BRACKET, EYE, ROTATIN	1
3	PFFZZ	9Y918	107525-1	BRACKET, EYE, ROTATIN	1
4	PFFZZ	9Y918	106470-3	BRACKET, EYE, NONROTA	1
5	PFFZZ	9Y918	107524	LIP, CLAMSHELL	1
6	PFFZZ	9Y918	106470-4	BRACKET, EYE, NONROTA	1
7	PFOZZ	96906	MS24665-872	PINCOTTER	2
8	PAOZZ	11083	281015	BOLT, MACHINE	2
9	PFOZZ	9Y918	107528	PIN, STRAIGHT, HEADLE	2
10	PFOZZ	96906	MS15003-1	FITTING, LUBRICATION	2
11	PFOZZ	96906	MS35338-51	WASHERILOCK	2
12	PFOZZ	96906	MS51967-23	NUT, PLAIN, HEXAGON	2
13	PFFZZ	9Y918	101166-1	SHAFT, STRAIGHT	1

END OF FIGURE

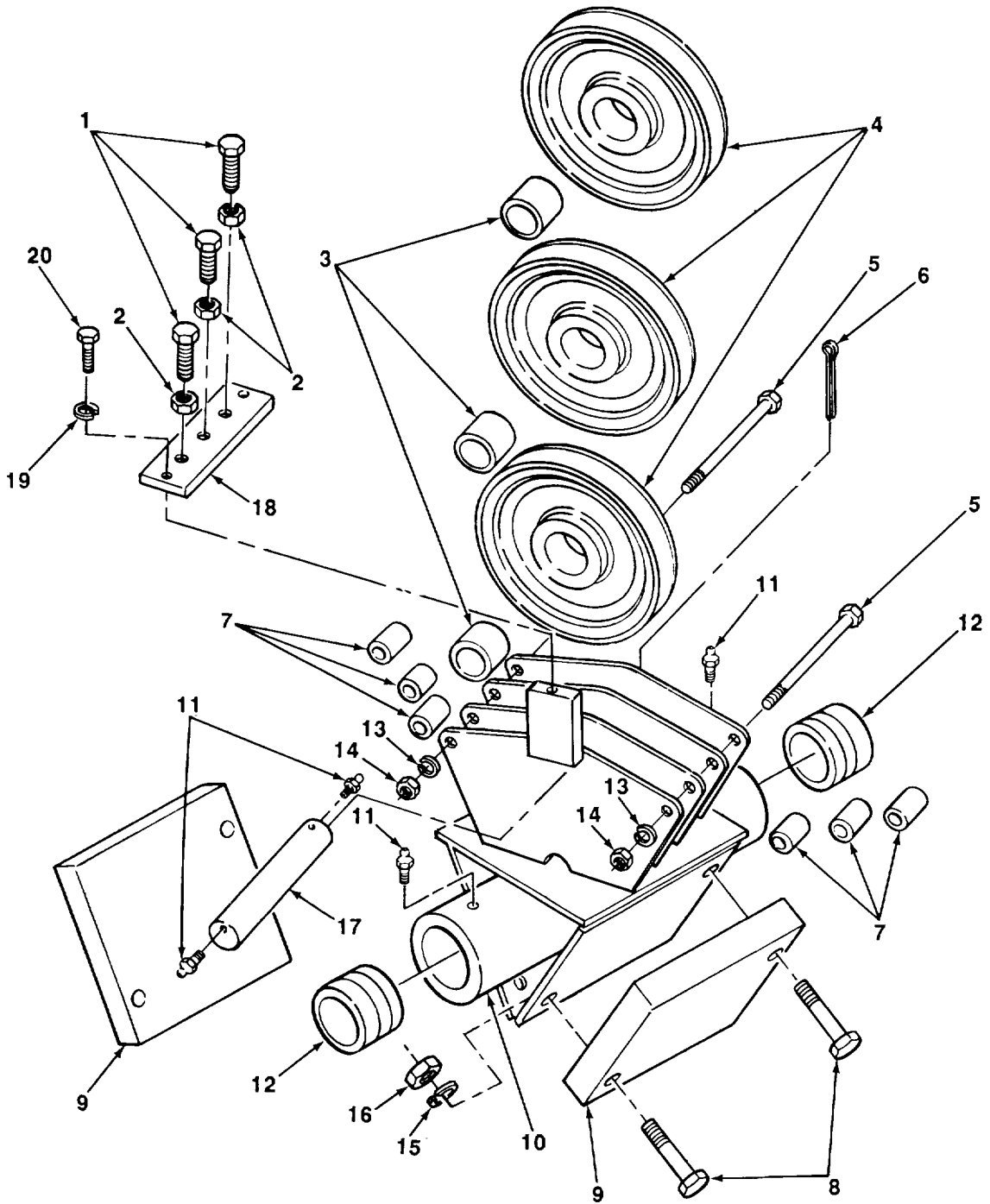
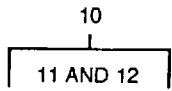

TA704548

FIGURE 3. LOWER BLOCK ASSEMBLY

SECTION II

(1) ITEM NO	(2) SMR CODE	(3) CAGEC	(4) PART NUMBER	(5) DESCRIPTION AND USABLE ON CODES (UOC)	(6) QTY
-------------------	--------------------	--------------	-----------------------	--	------------

GROUP 7411 CRANE DRAGLINE OR
CLA4SHELL ATTACHMENTS

FIG, 3 LOWER BLOCK ASSEMBLY

1	PFOZZ	9Y918	107540	SET SCREW.....	3
2	PFOZZ	96906	MS51967-26	NUT, PLAIN,HEXAGON	3
3	PAFZZ	9Y918	101192-1	BEARINGVSLEEVE.....	1
4	PBFZZ	9Y918	106475-1	PULLE, GROOVE	3
5	PFOZZ	9Y918	109053	BOLT,MACHINE	2
6	PFOZZ	96906	MS24665-872	PIN, COTTER	1
7	PFFZZ	9Y918	107523	BEARING, SLEEVE	6
8	PFOZZ	80204	81821BHIOOC600N	SCREW, CAP, HEXAGON H.....	4
9	PFOZZ	9Y918	101229-1	WEIGHT, COUNTERBALAN	2
10	PAOFF	9Y918	106471	BLOCK, TACKLE	1
11	PFOZZ	96906	MS15003-1	FITTING, LUBRICATION	4
12	PAFZZ	9Y918	100837-1 .	SUSHING, SLEEVE.....	1
13	PFOZZ	96906	MS35338-51	WASHER, LOCK	2
14	PFOZZ	96906	MS51967-23	NUT, PLAIN, HEXAGON	2
15	PFOZZ	96906	MS35338-53	WASHER, LOCK	4
16	PFOZZ	96906	MS51967-29	NUT, PLAIN, HEXAGON	4
17	PFFZZ	9Y918	107529	PIN,STRAIGHT,HEADLE.....	1
18	PFOZZ	9Y918	107541	PLATE, GROOVE CLEAN	3
19	PFOZZ	96906	MS35338-48	WASHER, LOCK	2
20	PFOZZ	80204	B1821BH050C150N	SCREW, CAP,HEXAGON H.....	2

END OF FIGURE

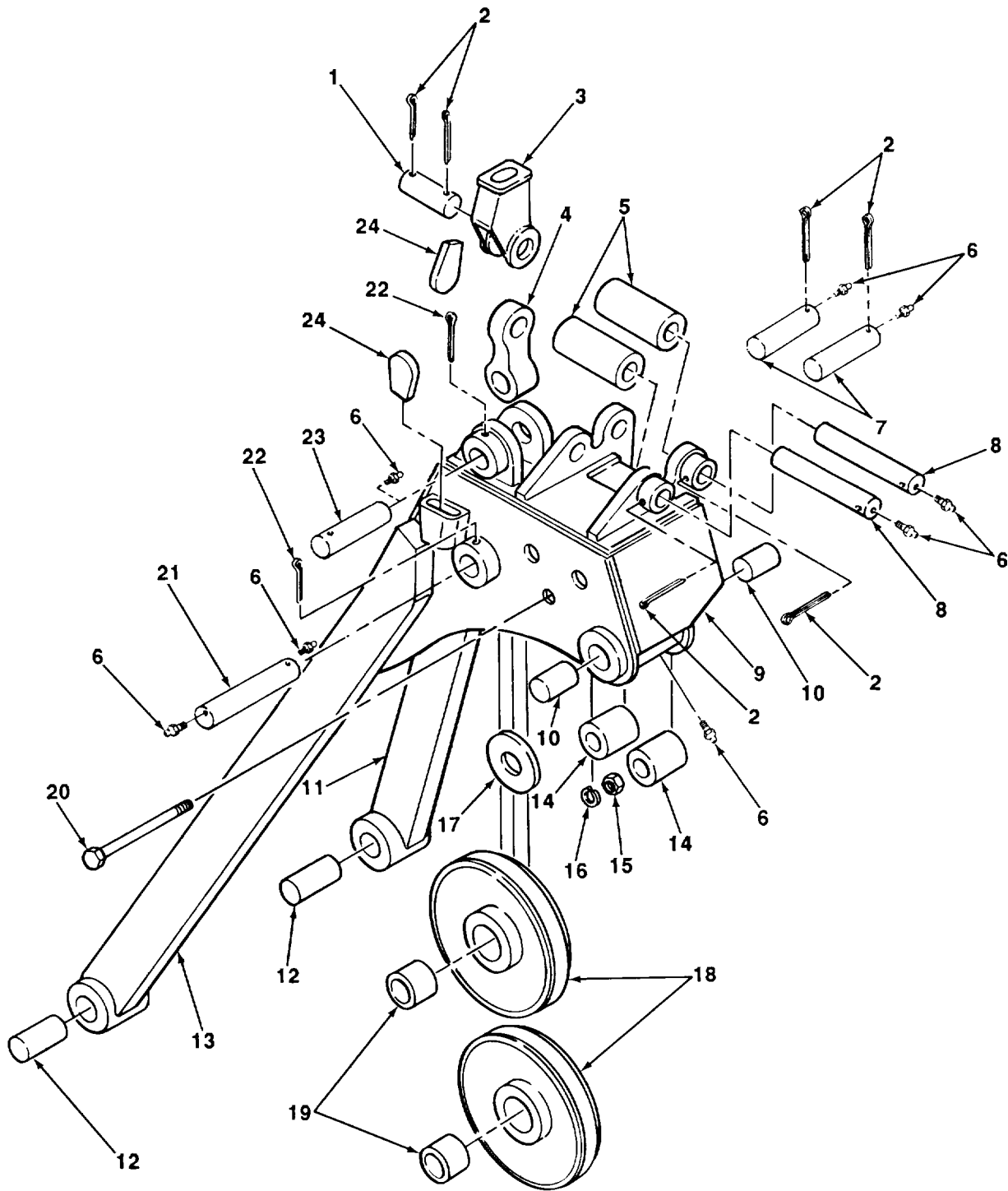
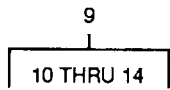

TA704549

FIGURE 4. HEAD ASSEMBLY.

SECTION II

TM5-3815-225-13&PC01

(1) ITEM NO	(2) SMR CODE	(3) CAGEC	(4) PART NUMBER	(5) DESCRIPTION AND USABLE ON CODES (UOC)	(6) QTY
GROUP 7411 CRANE DRAGLINE OR CLAMSHELL ATTACHMENTS					
FIG.4 HEAD ASSEMBLY					
1	PFOZZ	9Y918	101144-1	PIN,STRAIGHT,HEADLE.	1
2	PFOZZ	96906	MS24665-753	PIN,COTTER	6
3	PFOZZ	9Y918	103036	SOCKET,WIRE ROPE	1
4	PFOZZ	9Y918	103358	CONNECTING LINK, RIG	1
5	PFOZZ	9Y918	100598-4	ROLLER,LINEAR-ROTAR.....	2
6	PFOZZ	96906	MS15003-1	FITTING LUBRICATION,.....	8
7	PFOZZ	9Y918	101143-1	PIN STRAIGHT,HEADLE	2
8	PFOZZ	9Y918	101143-2	PIN STRAIG HT,HEADLE	2
9	PFFZZ	9Y918	106468-1	HEAD WELDMENT, CLAMS.....	1
10	PAFZZ	9Y918	100598-2	BUSHING,SLEEVE.....	2
11	PBFZZ	9Y918	106468-2	ARM CLAMSHELL BUCKE..	1
12	PAFZZ	9Y918	100598-3	BUSHING,SLEEVE	2
13	PBFZZ	9Y918	106468-3	ARM CLAMSHELL BUCKE.	1
14	PFOZZ	9Y918	100598-5	ROLLER,LINEAR-ROTAR	2
15	PFOZZ	96906	MS51967-29	NUT PLAT,NHEXAGON	2
16	PFOZZ	96906	MS35338-53	WASHER,LOCKO	1
17	PFFZZ	9Y918	100598-94	WASHER, FLAT.	1
18	PBFZZ	9Y918	106475-1	PULLEY,GROOVE	2
19	PAFZZ	9Y918	101192-1	BEARING,SLEEVE	2
20	XDOZZ	05573	NS46525-71/2	BOLTVMACHINE.....	1
21	PFFZZ	9Y918	107530	PIN,STRAIGHT,HEADLE.	1
22	PFOZZ	96906	MS24665-872	PIN,COTTER	2
23	PFOZZ	9Y918	107531	PIN, STRAIGHT HEADLE	1
24	PFOZZ	9Y918	102540	WEDGE,WIRE ROPE	2

END OF FIGURE

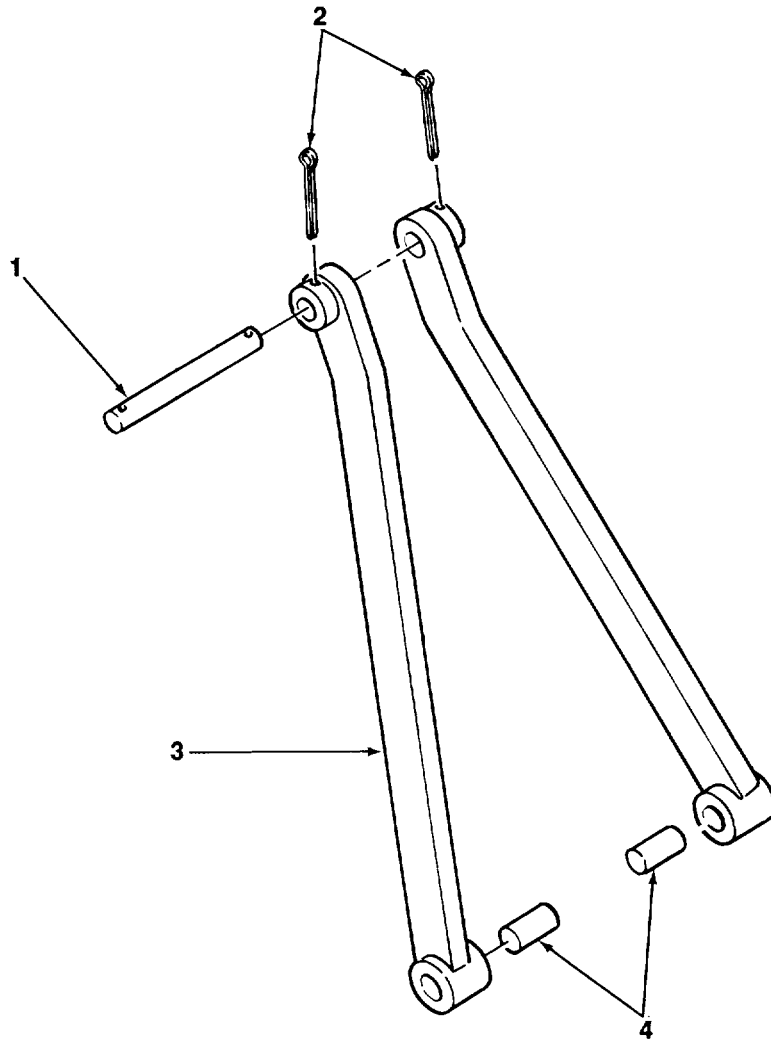

FIGURE 5. PIVOT ARM ASSEMBLY.

TA704550

SECTION II

TM5-3815-225-13&PC01

(1) ITEM NO	(2) SMR CODE	(3) CAGEC	(4) PART NUMBER	(5) DESCRIPTION AND USABLE ON CODES (UOC)	(6) QTY
-------------------	--------------------	--------------	-----------------------	--	------------

GROUP 7411 CRANE DRAGLINE OR
CLAMSHELL ATTACHMENTS

FIG.5 PIVOT ARM ASSEMBLY

1	PBFZZ	9Y918	101145-1	ROD, STRAIGHT, HEADLE	1
2	PFOZZ	96906	MS24665-872	PIN COTTER	2
3	PFFZZ	9Y918	107522	CONNECTING LINKGRIG	2
4	PAFZZ	9Y918	100598-3	BUSHING SLEEVE.....	1

END OF FIGURE

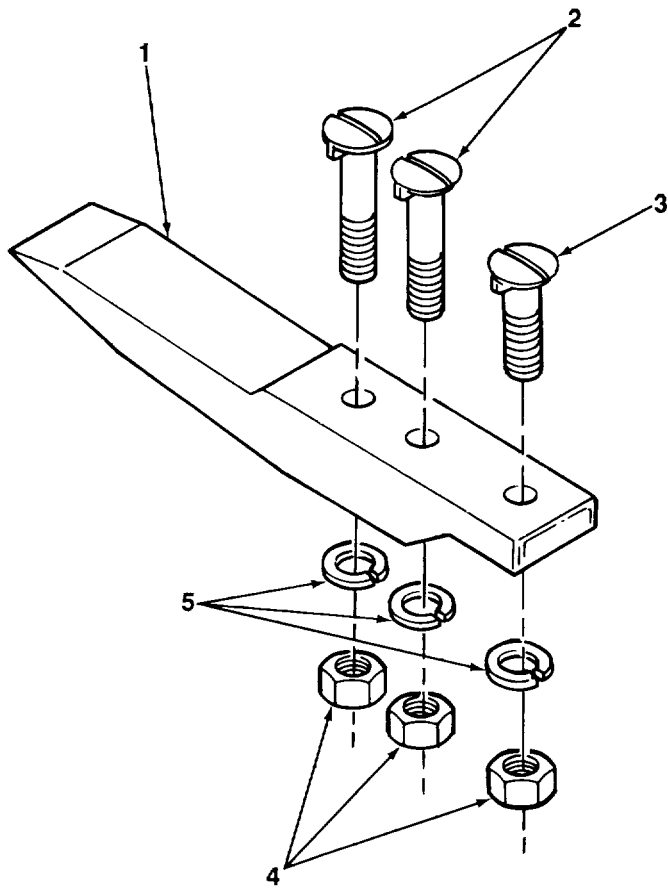

TA704551

FIGURE 6. TOOTH EQUIPMENT.

SECTION II

TM5-3815-225-13&PC01

(1) ITEM NO	(2) SMR CODE	(3) CAGEC	(4) PART NUMBER	(5) DESCRIPTION AND USABLE ON CODES (UOC)	(6) QTY
-------------------	--------------------	--------------	-----------------------	--	------------

GROUP 7411 CRANE DRAGLINE OR
CLAMSHELL ATTACHMENTS

FIG.6 TOOTH EQUIPMENT

1	PAOZZ	9Y918	102983	TOOTH,SURFACE RIPPI.....	6
2	PAOZZ	9Y918	102263	BOLT, KEY HEAD	12
3	PAOZZ	9Y918	102260	BOLTPKEY HEAD.....	6
4	PFOZZ	96906	MS51967-26	NUT,PLAIN,HEXAGON..	18
5	PFOZZ	96906	MS35338-52	WASHER,LOCK.	18

END OF FIGURE

CROSS-REFERENCE INDEXES

		NATIONAL STOCK NUMBER INDEX			
STOCK NUMBER	FIG.	ITEM	STOCK NUMBER	FIG.	ITEM.
4730-00-050-4208	1	8	5315-01-264-4270	2	7
	2	10		3	6
	3	11		4	22
	4	6		5	2
5315-00-059-0238	4	2	5315-01-264-4275	1	9
5305-00-071-2069	3	20		2	9
5306-00-426-3737	2	8	5315-01-264-4278	3	17
5310-00-584-5272	3	19	5315-01-264-4279	4	7
5310-00-584-7888	2	11	5340-01-264-4291	5	1
	3	13	5315-01-264-8519	4	21
5310-00-584-7889	3	15	4030-01-264-9201	4	24
	4	16	3120-01-265-0514	4	10
5310-00-754-2005	6	5	3120-01-265-0515	4	12
5310-00-762-6248	3	16		5	4
	4	15	5315-01-265-0527	4	8
5310-00-763-8921	2	12	3120-01-265-4833	3	7
	3	14	3120-01-265-4835	1	2
5310-00-880-8186	3	2		3	12
	6	4	4030-01-265-6218	4	3
5305-00-990-8416	3	8	5315-01-265-6226	4	1
3040-01-257-4920	2	13	3120-01-266-4090	3	3
3040-01-257-4940	3	9		4	19
3815-01-257-4959	2	4	3120-01-269-6108	4	14
3815-01-257-4967	2	1	3120-01-269-6109	4	5
3815-01-257-8814	6	1	3940-01-306-9405	3	10
3040-01-257-8908	4	4			
3040-01-257-8909	5	3			
3815-01-258-1075	1	6			
	2	5			
3815-01-258-1076	1	3			
3815-01-258-1077	1	1			
3815-01-258-2728	3	18			
3815-01-258-2729	4	9			
3815-01-258-2730	4	11			
	4	13			
3040-01-258-2787	1	5			
	2	3			
3040-01-258-2788	1	4			
	2	2			
3815-01-258-5142	1	7			
3815-01-258-5243	2	6			
3020-01-259-1643	3	4			
	4	18			
5306-01-264-3597	6	2			
5306-01-264-3598	6	3			
5315-01-264-3699	4	23			
5306-01-264-4196	3	5			
5305-01-264-4211	3	1			
5310-01-264-4225	4	17			
5315-01-264-4270	1	10			

CROSS-REFERENCE INDEXES

CAGEC	PART NUMBER	PART NUMBER INDEX		FIG.	ITEM
			STOCK NUMBER		
80204	B1821SH050C150N		5305-00-071-2069	3	20
80204	B1821BH10OC600N		5305-00-990-8416	3	8
96906	MS15003-1		4730-00-050-4208	1	8
				2	10
				3	11
				4	6
96906	MS24665-753		5315-00-059-0238	4	2
96906	MS24665-872		5315-01-264-4270	1	10
				2	7
				3	6
				4	22
				5	2
96906	MS35338-48		5310-00-584-5272	3	19
96906	MS35338-51		5310-00-584-7888	2	11
				3	13
96906	MS35338-52		5310-00-754-2005	6	5
96906	MS35338-53		5310-00-584-7889	3	15
				4	16
96906	MS51967-23		5310-00-763-8921	2	12
				3	14
96906	MS51967-26		5310-00-880-8186	3	2
				6	4
96906	MS51967-29		5310-00-762-6248	3	16
				4	15
05573	NS46525-71/2			4	20
9Y918	100598-2		3120-01-265-0514	4	10
9Y918	100598-3		3120-01-265-0515	4	12
				5	4
9Y918	100598-4		3120-01-269-6109	4	5
9Y918	100598-5		3120-01-269-6108	4	14
9Y918	100598-94		5310-01-264-4225	4	17
9Y918	100837-1		3120-01-265-4835	1	Z
				3	12
9Y918	101143-1		5315-01-264-4279	4	7
9Y918	101143-2		5315-01-265-0527	4	8
9Y918	101144-1		5315-01-265-6226	4	1
9Y918	101145-1		5340-01-264-4291	5	1
9Y918	101166-1		3040-01-257-4920	2	13
9Y918	101192-1		3120-01-266-4090	3	3
				4	19
9Y918	101229-1		3040-01-257-4940	3	9
9Y918	102260		5306-01-264-3598	6	3
9Y918	102263		5306-01-264-3597	6	2
9Y918	102540		4030-01-264-9201	4	24
9Y918	102983		3815-01-257-8814	6	1
9Y918	103036		4030-01-265-6218	4	3
9Y918	103358		3040-01-257-8908	4	4
9Y918	106468-1		3815-01-258-2729	4	9
9Y918	106468-2		3815-01-258-2730	4	11
9Y918	106468-3		3815-01-258-2730	4	13
9Y918	106470-1		3815-01-258-5142	1	7

CROSS-REFERENCE INDEXES

CAGEC	PART NUMBER	PART NUMBER INDEX		FIG.	ITEM
			STOCK NUMBER		
9Y918	106470-2		3815-01-258-1076	1	3
9Y918	106470-3		3815-01-257-4959	2	4
9Y918	106470-4		3815-01-258-5243	2	6
9Y918	106471		3940-01-306-9405	3	10
9Y918	106475-1		3020-01-259-1643	3	4
				4	18
9Y918	107522		3040-01-257-8909	5	3
9Y918	107523		3120-01-265-4833	3	7
9Y918	107524		3815-01-258-1075	1	6
				2	5
9Y918	107525-1		3040-01-258-2787	1	5
				2	3
9Y918	107525-2		3040-01-258-2788	1	4
				2	2
9Y918	107526		3815-01-257-4967	2	1
9Y918	107527		3815-01-258-1077	1	1
9Y918	107528		5315-01-264-4275	1	9
				2	9
9Y918	107529		5315-01-264-4278	3	17
9Y918	107530		5315-01-264-8519	4	21
9Y918	107531		5315-01-264-3699	4	23
9Y918	107540		5305-01-264-4211	3	1
9Y918	107541		3815-01-258-2728	3	18
9Y918	109053		5306-01-264-4196	3	5
11083	2B1015		5306-00-426-3737	2	8

CROSS-REFERENCE INDEXES

FIGURE AND ITEM NUMBER INDEX				
FIG.	ITEM	STOCK NUMBER	FSCM	PART NUMBER
1	1	3815-01-258-1077	9Y918	107527
1	2	3120-01-265-4835	9Y918	100837-1
1	3	3815-01-258-1076	9Y918	106470-2
1	4	3040-01-258-2788	9Y918	107525-
1	5	3040-01-258-2787	9Y918	107525-1
1	6	3815-01-258-1075	9Y918	107524
1	7	3815-01-258-5142	9Y918	106470-1
1	8	4730-00-050-4208	96906	MS15003-1
1	9	5315-01-264-4275	9Y918	107528
1	10	5315-01-264-4270	96906	MS24665-872
2	1	3815-01-257-4967	9Y918	107526
2	2	3040-01-258-2788	9Y918	107525-2
2	3	3040-01-258-2787	9Y918	107525-1
2	4	3815-01-257-4959	9Y918	106470-3
2	5	3815-01-258-1075	9Y918	107524
2	6	3815-01-258-5243	9Y918	106470-4
2	7	5315-01-264-4270	96906	MS24665-872
2	8	5306-00-426-3737	11083	281015
2	9	5315-01-264-4275	9Y918	107528
2	10	4730-00-050-4208	96906	MS15003-1
2	11	5310-00-584-7888	96906	MS35338-51
2	12	5310-00-763-8921	96906	MS51967-23
2	13	3040-01-257-4920	9Y918	101166-1
3	1	5305-01-264-4211	9Y918	107540
3	2	5310-00-880-8186	96906	MS51967-26
3	3	3120-01-266-4090	9Y918	101192-1
3	4	3020-01-259-1643	9Y918	106475-1
3	5	5306-01-264-4196	9Y918	109053
3	6	5315-01-264-4270	96906	MS24665-872
3	7	3120-01-265-4833	9Y918	107523
3	8	5305-00-990-8416	80204	B1821BH10OC600N
3	9	3040-01-257-4940	9Y918	101229-1
3	10	3940-01-306-9405	9Y918	106471
3	11	4730-00-050-4208	96906	MS15003-1
3	12	3120-01-265-4835	9Y918	100837-1
3	13	5310-00-584-7888	96906	MS35338-51
3	14	5310-00-763-8921	96906	M551967-23
3	15	5310-00-584-7889	96906	MS35338-53
3	16	5310-00-762-6248	96906	MS51967-29
3	17	5315-01-264-4278	9Y918	107529
3	18	3815-01-258-2728	9Y918	107541
3	19	5310-00-584-5272	96906	MS35338-48
3	20	5305-00-071-2069	80204	B1821BH05OC150N
4	1	5315-01-265-6226	9Y918	101144-1
4	2	5315-00-059-0238	96906	MS24665-753
4	3	4030-01-265-6218	9Y918	103036
4	4	3040-01-257-8908	9Y918	103358
4	5	3120-01-269-6109	9Y918	100598-4
4	6	4730-00-050-4208	96906	MS15003-1
4	7	5315-01-264-4279	9Y918	101143-1
4	8	5315-01-265-0527	9Y918	101143-2

CROSS-REFERENCE INDEXES

FIGURE AND ITEM NUMBER INDEX

FIG.	ITEM	STOCK NUMBER	FSCM	PART NUMBER
4	9	3815-01-258-2729	9Y918	106468-1
4	10	3120-01-265-0514	9Y918	100598-2
4	11	3815-01-258-2730	9Y918	106468-2
4	12	3120-01-265-0515	9Y918	100598-3
4	13	3815-01-258-2730	9Y918	106468-3
4	14	3120-01-269-6108	9Y918	100598-5
4	15	5310-00-762-6248	96906	MS51967-29
4	16	5310-00-584-7889	96906	MS35338-53
4	17	5310-01-264-4225	9Y918	100598-94
4	18	3020-01-259-1643	9Y918	106475-1
4	19	3120-01-266-4090	9Y918	101192-1
4	20		05573	NS46525-71/2
4	21	5315-01-264-8519	9Y918	107530
4	22	5315-01-264-4270	96906	MS24665-872
4	23	5315-01-264-3699	9Y918	107531
4	24	4030-01-264-9201	9Y918	102540
5	1	5340-01-264-4291	9Y918	101145-1
5	2	5315-01-264-4270	96906	MS24665-872
5	3	3040-01-257-8909	9Y918	107522
5	4	3120-01-265-0515	9Y918	100598-3
6	1	3815-01-257-8814	9Y918	102983
6	2	5306-01-264-3597	9Y918	102263
6	3	5306-01-264-3598	9Y918	102260
6	4	5310-00-880-8186	96906	MS51967-26
6	5	5310-00-754-2005	96906	MS35338-52

US Government Printing Office: 1993-746-017/80057

By Order of the Secretary of the Army:

CARL E. VUONO
General, United States Army
Chief of Staff

Official:

WILLIAM J. MEEHAN II
Brigadier General United States Army
The Adjutant General

Distribution:

To be distributed in accordance with DA Form 12-25A-R, Maintenance requirements for Operator, Unit, Direct Support and General Support for Bucket, Clamshell and Bucket, Dragline, 3/4 cu. yd.

*U.S. GOVERNMENT PRINTING OFFICE: 1989 643-025/80091

RECOMMENDED CHANGES TO EQUIPMENT TECHNICAL PUBLICATIONS



THEN... JOT DOWN THE DOPE ABOUT IT ON THIS FORM, CAREFULLY TEAR IT OUT, FOLD IT AND DROP IT IN THE MAIL!

SOMETHING WRONG WITH THIS PUBLICATION?

FROM: (PRINT YOUR UNIT'S COMPLETE ADDRESS)

DATE SENT

PUBLICATION NUMBER

TM 11-5825-270-10

PUBLICATION DATE

23 Jul 81

PUBLICATION TITLE

Radio Frequency R-2176/FRN

BE EXACT... PIN-POINT WHERE IT IS

PAGE NO.

PARA-GRAPH

FIGURE NO.

TABLE NO.

IN THIS SPACE TELL WHAT IS WRONG AND WHAT SHOULD BE DONE ABOUT IT:

TEAR ALONG PERFORATED LINE

PRINTED NAME, GRADE OR TITLE, AND TELEPHONE NUMBER

SIGN HERE:

DA FORM 2028-2
1 JUL 79

PREVIOUS EDITIONS ARE OBSOLETE.

P.S.—IF YOUR OUTFIT WANTS TO KNOW ABOUT YOUR RECOMMENDATION MAKE A CARBON COPY OF THIS AND GIVE IT TO YOUR HEADQUARTERS.

THE METRIC SYSTEM AND EQUIVALENTS

LINEAR MEASURE

- 1 Centimeter = 10 Millimeters 0.01 Meters =0.3937 Inches
- 1 Meter= 100 Centimeters=1000 Millimeters=39.37 Inches
- 1 Kilometer=1000 Meters0.621 Miles

SQUARE MEASURE

- 1 Sq Centimeter =100 Sq Millimeters= 0.155 Sq Inches
- 1 Sq Meter= 1-000 Sq Centimeters= 10.76 Sq Feet
- 1 Sq Kilometer=1,000,000 Sq Meters0.386 Sq Miles

WEIGHTS

- 1 Gram=0.001 Kilograms=1000 Milligrams=0.035 Ounces
- 1 Kilogram=1000 Grams=2.2 Lb
- 1 Metric Ton =1000 Kilograms 1 Megagram =1.1 Short Tons

CUBIC MEASURE

- 1 Cu Centimeter =1000 Cu Millimeters=0.06 Cu Inches
- 1 Cu Meter =1,000,000Cu Centimeters=35.31 Cu Feet

LIQUID MEASURE

- 1 Milliliter=0.001 Liters 0.0338 Fluid Ounces
- 1 Liter=1000 Milliliters =33.82 Fluid Ounces

TEMPERATURE

- $5/9(°F-32)=C$
- 212°Fahrenheit is equivalent to 100° Celsius
- 90° Fahrenheit is equivalent to 32.2° Celsius
- 32° Fahrenheit is equivalent to 0° Celsius
- $9/5 C° +32=F°$

APPROXIMATE CONVERSION FACTORS

<u>TO CHANGE</u>	<u>TO</u>	<u>MULTIPLY BY</u>
Inches.....	Centimeters.....	2.540
Feet.....	Meters.....	0.305
Yards.....	Meters.....	0.914
Miles.....	Kilometers.....	1.609
Square Inches.....	Square Centimeters.....	6.451
Square Feet.....	Square Meters.....	0.093
Square Yards.....	Square Meters.....	0.836
Square Miles.....	Square Kilometers.....	2.590
Acres.....	Square Hectometers.....	0.405
Cubic Feet.....	Cubic Meters.....	0.028
Cubic Yards.....	Cubic Meters.....	0.765
Fluid Ounces.....	Milliliters.....	29.573
Pints.....	Liters.....	0.473
Quarts.....	Liters.....	0.946
Gallons.....	Liters.....	3.785
Ounces.....	Grams.....	28.349
Pounds.....	Kilograms.....	0.454
Short Tons.....	Metric Tons.....	0.907
Pound-Feet.....	Newton-Meters.....	1.356
Pounds per Square Inch.....	Kilopascals.....	6.895
Miles per Gallon.....	Kilometers per Liter.....	0.425
Miles per Hour.....	Kilometers per Hour.....	1.609
<u>TO CHANGE</u>	<u>TO</u>	<u>MULTIPLY BY</u>
Centimeters	Inches.....	0.394
Meters	Feet.....	3.280
Meters	Yards.....	1.094
Kilometers	Miles.....	0.621
Square Centimeters	Square Inches.....	0.155
Square Meters	Square Feet.....	10.764
Square Meters	Square Yards.....	1.196
Square Kilometers	Square Miles.....	0.386
Square Hectometers	Acres.....	2.471
Cubic Meters	Cubic Feet.....	35.315
Cubic Meters	Cubic Yards.....	1.308
Milliliters	Fluid Ounces.....	0.034
Liters	Pints.....	2.113
Liters	Quarts.....	1.057
Liters	Gallons.....	0.264
Grams	Ounces.....	0.035
Kilograms	Pounds.....	2.205
Metric Tons	Short Tons.....	1.102
Newton-Meters	Pound-Feet.....	0.738
Kilopascals	Pounds per Square Inch.....	0.145
Kilometers per Liter	Miles per Gallon.....	2.354
Kilometers per Hour	Miles per Hour.....	0.621

PIN: 065189-001